

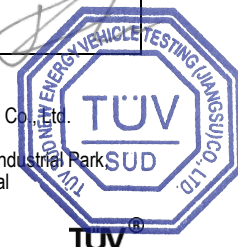

TEST REPORT ANSI/CAN/UL 9540A:2019 TÜV SÜD Test Report for Test Method for Evaluating Thermal Runaway Fire Propagation in Battery Energy Storage Systems on Unit Level					
Report No.:	5061925025713-00				
Date of issue:	2026-01-04				
Project handler:	Zhu, Jiacheng				
Supervisor:	You, Duo				
Testing laboratory:	TÜV SÜD New Energy Vehicle Testing (Jiangsu) Co., Ltd.				
Address:	Building A, No.15 Factory, Jintong International Industrial Park, No.8, Xihu Road, Wujin National Hi-tech Industrial Development Zone, Changzhou, Jiangsu, China				
Testing location:	Chuweineng Testing Technology (Shanghai) Co., Ltd. Building 3, No. 1065, Beihe Road, Jiading District, Shanghai				
Client:	Shanghai PYTES Energy Co., Ltd.				
Client number:	003364				
Address:	No. 3492 Jinqian Road, Fengxian District, 201406 Shanghai, PEOPLE'S REPUBLIC OF CHINA				
Contact person:	Yang, Lijuan				
Standard:	ANSI/CAN/UL 9540A:2019 Fourth Edition (4Ed)				
TRF number and revision:	TRF ANSI/CAN/UL 9540A:2019 Rev 0				
TRF originated by:	TÜV SÜD Product Service				
Copyright blank test report:	This test report is based on the content of the standard (see above). The test report considered selected clauses of the a.m. standard(s) and experience gained with product testing. It was prepared by TÜV SÜD Product Service.				
General disclaimer:	TÜV SÜD Group takes no responsibility for and will not assume liability for damages resulting from the reader's interpretation of the reproduced material due to its placement and context. This test report may only be quoted in full. Any use for advertising purposes must be granted in writing. This report is the result of a single examination of the object in question and is not generally applicable evaluation of the quality of other products in regular production.				
Scheme:	<input type="checkbox"/> TUV Mark <input type="checkbox"/> cTUV Mark (SCC) <input type="checkbox"/> TUVus Mark (NRTL) <input type="checkbox"/> GS Mark <input checked="" type="checkbox"/> without certification <input checked="" type="checkbox"/> other: TÜV SÜD Test Report from witness test <input type="checkbox"/> AoC/CoC for EU-Directive / EU-Regulation:				
Non-standard test method:	<input checked="" type="checkbox"/> No <input type="checkbox"/> Yes, see details under <i>Summary of testing</i>				
National deviations:	N/A				
Compiled by:	Zhu, Jiacheng	Compiled by:	You, Duo	Approved by:	Frank, Marco
(+ signature)	<i>Zhu Jiacheng</i>	(+ signature)	<i>You Duo</i>	(+ signature)	<i>M. Frank</i>





Number of pages (Report):	77
Number of pages (Attachments):	28 (page 50 – 77)

Test sample:	Batteries	
Type of test object:	Battery cabinet	
Trademark:		
Model and/ or type reference:	HV48100 SE 1P3S, HV48100 SE 1P4S, HV48100 SE 1P5S, HV48100 SE 1P6S, HV48100 SE 1P7S, HV48100 SE 1P8S, HV48100 SE 1P9S, HV48100 SE 1P10S, HV48100 SE 1P11S, HV48100 SE 1P12S, HV48100 SE 1P13S, HV48100 SE 1P14S, HV48100 SE 1P15S, HV48100 SE 2P3S, HV48100 SE 2P4S, HV48100 SE 2P5S, HV48100 SE 2P6S, HV48100 SE 2P7S,	HV48100 SE Lite 1P3S HV48100 SE Lite 1P4S HV48100 SE Lite 1P5S HV48100 SE Lite 1P6S HV48100 SE Lite 1P7S HV48100 SE Lite 1P8S HV48100 SE Lite 1P9S HV48100 SE Lite 1P10S HV48100 SE Lite 1P11S HV48100 SE Lite 1P12S HV48100 SE Lite 1P13S HV48100 SE Lite 1P14S HV48100 SE Lite 1P15S HV48100 SE Lite 2P3S HV48100 SE Lite 2P4S HV48100 SE Lite 2P5S HV48100 SE Lite 2P6S HV48100 SE Lite 2P7S
Rating(s):	HV48100 SE 1P3S: 153.6 Vd.c HV48100 SE 1P4S: 204.8 Vd.c HV48100 SE 1P5S: 256 Vd.c HV48100 SE 1P6S: 307.2 Vd.c HV48100 SE 1P7S: 358.4 Vd.c. HV48100 SE 1P8S: 409.6 Vd.c. HV48100 SE 1P9S: 460.8 Vd.c. HV48100 SE 1P10S: 512 Vd.c. HV48100 SE 1P11S: 563.2 Vd.c. HV48100 SE 1P12S: 614.4 Vd.c. HV48100 SE 1P13S: 665.6 Vd.c. HV48100 SE 1P14S: 716.8 Vd.c.	100 Ah



	HV48100 SE 1P15S:	768 Vd.c.	100 Ah
	HV48100 SE Lite 1P3S	153.6 Vd.c	
	HV48100 SE Lite 1P4S	204.8 Vd.c	
	HV48100 SE Lite 1P5S:	256 Vd.c	
	HV48100 SE Lite 1P6S:	307.2 Vd.c	
	HV48100 SE Lite 1P7S:	358.4 Vd.c.	
	HV48100 SE Lite 1P8S:	409.6 Vd.c.	
	HV48100 SE Lite 1P9S:	460.8 Vd.c.	
	HV48100 SE Lite 1P10S:	512 Vd.c.	
	HV48100 SE Lite 1P11S:	563.2 Vd.c.	
	HV48100 SE Lite 1P12S:	614.4 Vd.c.	
	HV48100 SE Lite 1P13S:	665.6 Vd.c.	
	HV48100 SE Lite 1P14S:	716.8 Vd.c.	
	HV48100 SE Lite 1P15S:	768 Vd.c.	
	HV48100 SE 2P3S:	153.6 Vd.c	
	HV48100 SE 2P4S:	204.8 Vd.c	
	HV48100 SE 2P5S:	256 Vd.c	
	HV48100 SE 2P6S:	307.2 Vd.c	
	HV48100 SE 2P7S:	358.4 Vd.c.	
	HV48100 SE Lite 2P3S:	153.6 Vd.c	
HV48100 SE Lite 2P4S:	204.8 Vd.c		
HV48100 SE Lite 2P5S:	256 Vd.c		
HV48100 SE Lite 2P6S:	307.2 Vd.c		
HV48100 SE Lite 2P7S:	358.4 Vd.c.		

Manufacturer:	Shanghai PYTES Energy Co., Ltd.
Manufacturer number:	003364
Address:	No. 3492 Jinqian Road, Fengxian District, 201406 Shanghai, PEOPLE'S REPUBLIC OF CHINA
Name and address of factory(ies)	
Shanghai PYTES Energy Co., Ltd.	
No. 3492 Jinqian Road, Fengxian District, 201406 Shanghai, PEOPLE'S REPUBLIC OF CHINA	

Sub-contractors / tests (clause):	N/A
Name:	N/A
Order description:	<input type="checkbox"/> Complete test according to TRF



	<input type="checkbox"/> Partial test according to manufacturer's specifications <input type="checkbox"/> Preliminary test <input type="checkbox"/> Spot check <input checked="" type="checkbox"/> Others: Witness test
Date of order:	2024-10-22
Date of receipt of test item:	2025-06-16
Date(s) of performance of test:	2025-06-17 to 2025-06-18
Test item particulars:	
According to Unit Level of ANSI/CAN/UL 9540A:2019 Fourth Edition.	
Purpose of the product (description of intended use):	
Battery cabinets, models: HV48100 SE 1P3S, HV48100 SE Lite 1P3S, HV48100 SE 1P4S, HV48100 SE Lite 1P4S, HV48100 SE 1P5S, HV48100 SE Lite 1P5S, HV48100 SE 1P6S, HV48100 SE Lite 1P6S, HV48100 SE 1P7S, HV48100 SE Lite 1P7S, HV48100 SE 1P8S, HV48100 SE Lite 1P8S, HV48100 SE 1P9S, HV48100 SE Lite 1P9S, HV48100 SE 1P10S, HV48100 SE Lite 1P10S, HV48100 SE 1P11S, HV48100 SE Lite 1P11S, HV48100 SE 1P12S, HV48100 SE Lite 1P12S, HV48100 SE 1P13S, HV48100 SE Lite 1P13S, HV48100 SE 1P14S, HV48100 SE Lite 1P14S, HV48100 SE 1P15S, HV48100 SE Lite 1P15S, HV48100 SE 2P3S, HV48100 SE Lite 2P3S, HV48100 SE 2P4S, HV48100 SE Lite 2P4S, HV48100 SE 2P5S, HV48100 SE Lite 2P5S, HV48100 SE 2P6S, HV48100 SE Lite 2P6S, HV48100 SE 2P7S, HV48100 SE Lite 2P7S are used for residential & non-residential applications, both for indoor & outdoor use.	



Remark:

The models HV48100 SE series and HV48100 SE Lite series are identical in all electrical principles and structural aspects except for fire protection system configuration:

- 1.HV48100 SE series is equipped with an integrated fire protection system (powered externally).
- 2.HV48100 SE Lite series omits the fire protection system from its cabinet.

The models: HV48100 SE 2P3S and HV48100 SE Lite 2P3S, HV48100 SE 2P4S and HV48100 SE Lite 2P4S, HV48100 SE 2P5S and HV48100 SE Lite 2P5S, HV48100 SE 2P6S and HV48100 SE Lite 2P6S, HV48100 SE 2P7S and HV48100 SE Lite 2P7S each incorporate two independent battery systems, models: HV48100 SE BMU-3, HV48100 SE BMU-4, HV48100 SE BMU-5, HV48100 SE BMU-6 and HV48100 SE BMU-7.

(The two battery systems, HV48100 SE BMU-3, HV48100 SE BMU-4, HV48100 SE BMU-5, HV48100 SE BMU-6 and HV48100 SE BMU-7, connected in parallel via a combiner box or PCS outside the battery cabinet, while the two battery systems inside the battery remain independent without mutual interference.)

Model: HV48100 SE BMU-3, HV48100 SE BMU-4, HV48100 SE BMU-5, HV48100 SE BMU-6, HV48100 SE BMU-7 respectively consist of 3,4,5,6,7 Rechargeable Li-ion Battery Modules (model: HV48100 SE BMU) connected in series with the HV box (model: HV48100 SE BCU).

Due to the identical electrical principles and structural design (except as stated above) and the use of identical critical components, only HV48100 SE 1P15S was tested. The test results are considered representative of the performance of all listed models. The unit-level test results in this report were generated from testing model HV48100 SE 1P15S which is the unit with the largest quantity of batteries.

The test was conducted using the configuration with 1P15S inside the battery cabinet. This configuration features the maximum number of modules among all models and is subject to the most stringent requirements for thermal runaway testing, hence its selection for the test.

The unit-level testing is conducted under the final installation conditions.



Characteristic data (not shown on the marking plate):			
Product name	Battery cabinet		
Type/model	HV48100 SE 1P3S,	HV48100 SE Lite 1P3S	
	HV48100 SE 1P4S,	HV48100 SE Lite 1P4S	
	HV48100 SE 1P5S,	HV48100 SE Lite 1P5S	
	HV48100 SE 1P6S,	HV48100 SE Lite 1P6S	
	HV48100 SE 1P7S,	HV48100 SE Lite 1P7S	
	HV48100 SE 1P8S,	HV48100 SE Lite 1P8S	
	HV48100 SE 1P9S,	HV48100 SE Lite 1P9S	
	HV48100 SE 1P10S,	HV48100 SE Lite 1P10S	
	HV48100 SE 1P11S,	HV48100 SE Lite 1P11S	
	HV48100 SE 1P12S,	HV48100 SE Lite 1P12S	
	HV48100 SE 1P13S,	HV48100 SE Lite 1P13S	
	HV48100 SE 1P14S,	HV48100 SE Lite 1P14S	
	HV48100 SE 1P15S,	HV48100 SE Lite 1P15S	
	HV48100 SE 2P3S,	HV48100 SE Lite 2P4S	
	HV48100 SE 2P4S,	HV48100 SE Lite 2P4S	
	HV48100 SE 2P5S,	HV48100 SE Lite 2P5S	
	HV48100 SE 2P6S,	HV48100 SE Lite 2P6S	
HV48100 SE 2P7S,	HV48100 SE Lite 2P7S		
Nominal voltage	HV48100 SE 1P3S,	HV48100 SE Lite 1P3S:	153.6 Vd.c
	HV48100 SE 1P4S,	HV48100 SE Lite 1P4S:	204.8 Vd.c
	HV48100 SE 1P5S,	HV48100 SE Lite 1P5S:	256 Vd.c
	HV48100 SE 1P6S,	HV48100 SE Lite 1P6S:	307.2 Vd.c
	HV48100 SE 1P7S,	HV48100 SE Lite 1P7S:	358.4 Vd.c.
	HV48100 SE 1P8S,	HV48100 SE Lite 1P8S:	409.6 Vd.c.
	HV48100 SE 1P9S,	HV48100 SE Lite 1P9S:	460.8 Vd.c.
	HV48100 SE 1P10S,	HV48100 SE Lite 1P10S:	512 Vd.c.
	HV48100 SE 1P11S,	HV48100 SE Lite 1P11S:	563.2 Vd.c.
	HV48100 SE 1P12S,	HV48100 SE Lite 1P12S:	614.4 Vd.c.
	HV48100 SE 1P13S,	HV48100 SE Lite 1P13S:	665.6 Vd.c.
	HV48100 SE 1P14S,	HV48100 SE Lite 1P14S:	716.8 Vd.c.
	HV48100 SE 1P15S,	HV48100 SE Lite 1P15S:	768 Vd.c.
	HV48100 SE 2P3S,	HV48100 SE Lite 2P3S:	153.6 Vd.c
	HV48100 SE 2P4S,	HV48100 SE Lite 2P4S:	204.8 Vd.c
HV48100 SE 2P5S,	HV48100 SE Lite 2P5S:	256 Vd.c	



	HV48100 SE 2P6S, HV48100 SE 2P7S,	HV48100 SE Lite 2P6S: HV48100 SE Lite 2P7S:	307.2 Vd.c 358.4 Vd.c.	
Rated capacity	HV48100 SE 1P3S, HV48100 SE 1P4S, HV48100 SE 1P5S, HV48100 SE 1P6S, HV48100 SE 1P7S, HV48100 SE 1P8S, HV48100 SE 1P9S, HV48100 SE 1P10S, HV48100 SE 1P11S, HV48100 SE 1P12S, HV48100 SE 1P13S, HV48100 SE 1P14S, HV48100 SE 1P15S,	HV48100 SE Lite 1P3S: HV48100 SE Lite 1P4S: HV48100 SE Lite 1P5S: HV48100 SE Lite 1P6S: HV48100 SE Lite 1P7S: HV48100 SE Lite 1P8S: HV48100 SE Lite 1P9S: HV48100 SE Lite 1P10S: HV48100 SE Lite 1P11S: HV48100 SE Lite 1P12S: HV48100 SE Lite 1P13S: HV48100 SE Lite 1P14S: HV48100 SE Lite 1P15S:	100 Ah	
	HV48100 SE 2P3S, HV48100 SE 2P4S, HV48100 SE 2P5S, HV48100 SE 2P6S, HV48100 SE 2P7S,	HV48100 SE Lite 2P3S: HV48100 SE Lite 2P4S: HV48100 SE Lite 2P5S: HV48100 SE Lite 2P6S: HV48100 SE Lite 2P7S:	100 Ah × 2	
	Charging voltage specified by manufacturer	HV48100 SE 1P3S, HV48100 SE 1P4S, HV48100 SE 1P5S, HV48100 SE 1P6S, HV48100 SE 1P7S, HV48100 SE 1P8S, HV48100 SE 1P9S, HV48100 SE 1P10S, HV48100 SE 1P11S, HV48100 SE 1P12S, HV48100 SE 1P13S, HV48100 SE 1P14S, HV48100 SE 1P15S, HV48100 SE 2P3S, HV48100 SE 2P4S, HV48100 SE 2P5S,	HV48100 SE Lite 1P3S: HV48100 SE Lite 1P4S: HV48100 SE Lite 1P5S: HV48100 SE Lite 1P6S: HV48100 SE Lite 1P7S: HV48100 SE Lite 1P8S: HV48100 SE Lite 1P9S: HV48100 SE Lite 1P10S: HV48100 SE Lite 1P11S: HV48100 SE Lite 1P12S: HV48100 SE Lite 1P13S: HV48100 SE Lite 1P14S: HV48100 SE Lite 1P15S: HV48100 SE Lite 2P3S: HV48100 SE Lite 2P4S: HV48100 SE Lite 2P5S:	168 V 224 V 280 V 336 V 392 V 448 V 504 V 560 V 616 V 672 V 728 V 784 V 840 V 168 V 224 V 280 V



	HV48100 SE 2P6S, HV48100 SE Lite 2P6S: 336 V HV48100 SE 2P7S, HV48100 SE Lite 2P7S: 392 V or any cell reaches 3.55 V
Upper limit charging voltage	3.65V for cell
Charging current specified by manufacturer	HV48100 SE 1P3S, HV48100 SE Lite 1P3S: HV48100 SE 1P4S, HV48100 SE Lite 1P4S: HV48100 SE 1P5S, HV48100 SE Lite 1P5S: HV48100 SE 1P6S, HV48100 SE Lite 1P6S: HV48100 SE 1P7S, HV48100 SE Lite 1P7S: HV48100 SE 1P8S, HV48100 SE Lite 1P8S: HV48100 SE 1P9S, HV48100 SE Lite 1P9S: 50 A HV48100 SE 1P10S, HV48100 SE Lite 1P10S: HV48100 SE 1P11S, HV48100 SE Lite 1P11S: HV48100 SE 1P12S, HV48100 SE Lite 1P12S: HV48100 SE 1P13S, HV48100 SE Lite 1P13S: HV48100 SE 1P14S, HV48100 SE Lite 1P14S: HV48100 SE 1P15S, HV48100 SE Lite 1P15S:
	HV48100 SE 2P3S, HV48100 SE Lite 2P3S: HV48100 SE 2P4S, HV48100 SE Lite 2P4S: HV48100 SE 2P5S, HV48100 SE Lite 2P5S: 50 A × 2 HV48100 SE 2P6S, HV48100 SE Lite 2P6S: HV48100 SE 2P7S, HV48100 SE Lite 2P7S:
Maximum continuous charging current	HV48100 SE 1P3S, HV48100 SE Lite 1P3S: HV48100 SE 1P4S, HV48100 SE Lite 1P4S: HV48100 SE 1P5S, HV48100 SE Lite 1P5S: HV48100 SE 1P6S, HV48100 SE Lite 1P6S: HV48100 SE 1P7S, HV48100 SE Lite 1P7S: HV48100 SE 1P8S, HV48100 SE Lite 1P8S: 50 A HV48100 SE 1P9S, HV48100 SE Lite 1P9S: HV48100 SE 1P10S, HV48100 SE Lite 1P10S: HV48100 SE 1P11S, HV48100 SE Lite 1P11S: HV48100 SE 1P12S, HV48100 SE Lite 1P12S: HV48100 SE 1P13S, HV48100 SE Lite 1P13S: HV48100 SE 1P14S, HV48100 SE Lite 1P14S:



	HV48100 SE 1P15S,	HV48100 SE Lite 1P15S:	
	HV48100 SE 2P3S,	HV48100 SE Lite 2P3S:	
	HV48100 SE 2P4S,	HV48100 SE Lite 2P4S:	
	HV48100 SE 2P5S,	HV48100 SE Lite 2P5S:	50 A × 2
	HV48100 SE 2P6S,	HV48100 SE Lite 2P6S:	
	HV48100 SE 2P7S,	HV48100 SE Lite 2P7S:	
Discharging current specified by manufacturer	HV48100 SE 1P3S,	HV48100 SE Lite 1P3S:	
	HV48100 SE 1P4S,	HV48100 SE Lite 1P4S:	
	HV48100 SE 1P5S,	HV48100 SE Lite 1P5S:	
	HV48100 SE 1P6S,	HV48100 SE Lite 1P6S:	
	HV48100 SE 1P7S,	HV48100 SE Lite 1P7S:	
	HV48100 SE 1P8S,	HV48100 SE Lite 1P8S:	
	HV48100 SE 1P9S,	HV48100 SE Lite 1P9S:	50 A
	HV48100 SE 1P10S,	HV48100 SE Lite 1P10S:	
	HV48100 SE 1P11S,	HV48100 SE Lite 1P11S:	
	HV48100 SE 1P12S,	HV48100 SE Lite 1P12S:	
	HV48100 SE 1P13S,	HV48100 SE Lite 1P13S:	
	HV48100 SE 1P14S,	HV48100 SE Lite 1P14S:	
	HV48100 SE 1P15S,	HV48100 SE Lite 1P15S:	
		HV48100 SE 2P3S,	HV48100 SE Lite 2P3S:
	HV48100 SE 2P4S,	HV48100 SE Lite 2P4S:	
	HV48100 SE 2P5S,	HV48100 SE Lite 2P5S:	50 A × 2
	HV48100 SE 2P6S,	HV48100 SE Lite 2P6S:	
	HV48100 SE 2P7S,	HV48100 SE Lite 2P7S:	
Maximum continuous discharging current	HV48100 SE 1P3S,	HV48100 SE Lite 1P3S:	
	HV48100 SE 1P4S,	HV48100 SE Lite 1P4S:	
	HV48100 SE 1P5S,	HV48100 SE Lite 1P5S:	
	HV48100 SE 1P6S,	HV48100 SE Lite 1P6S:	
	HV48100 SE 1P7S,	HV48100 SE Lite 1P7S:	
	HV48100 SE 1P8S,	HV48100 SE Lite 1P8S:	50 A
	HV48100 SE 1P9S,	HV48100 SE Lite 1P9S:	
	HV48100 SE 1P10S,	HV48100 SE Lite 1P10S:	
	HV48100 SE 1P11S,	HV48100 SE Lite 1P11S:	
	HV48100 SE 1P12S,	HV48100 SE Lite 1P12S:	
	HV48100 SE 1P13S,	HV48100 SE Lite 1P13S:	



	HV48100 SE 1P14S, HV48100 SE Lite 1P14S: HV48100 SE 1P15S, HV48100 SE Lite 1P15S: HV48100 SE 2P3S, HV48100 SE Lite 2P3S: HV48100 SE 2P4S, HV48100 SE Lite 2P4S: HV48100 SE 2P5S, HV48100 SE Lite 2P5S: 50 A × 2 HV48100 SE 2P6S, HV48100 SE Lite 2P6S: HV48100 SE 2P7S, HV48100 SE Lite 2P7S:
End of discharge voltage	HV48100 SE 1P3S, HV48100 SE Lite 1P3S: 136.6 V HV48100 SE 1P4S, HV48100 SE Lite 1P4S: 182 V HV48100 SE 1P5S, HV48100 SE Lite 1P5S: 227.5 V HV48100 SE 1P6S, HV48100 SE Lite 1P6S: 273 V HV48100 SE 1P7S, HV48100 SE Lite 1P7S: 318.5 V HV48100 SE 1P8S, HV48100 SE Lite 1P8S: 364 V HV48100 SE 1P9S, HV48100 SE Lite 1P9S: 409.5 V HV48100 SE 1P10S, HV48100 SE Lite 1P10S: 455 V HV48100 SE 1P11S, HV48100 SE Lite 1P11S: 500.5 V HV48100 SE 1P12S, HV48100 SE Lite 1P12S: 546 V HV48100 SE 1P13S, HV48100 SE Lite 1P13S: 591.5 V HV48100 SE 1P14S, HV48100 SE Lite 1P14S: 637 V HV48100 SE 1P15S, HV48100 SE Lite 1P15S: 682.5 V HV48100 SE 2P3S, HV48100 SE Lite 2P3S: 136.6 V HV48100 SE 2P4S, HV48100 SE Lite 2P4S: 182 V HV48100 SE 2P5S, HV48100 SE Lite 2P5S: 227.5 V HV48100 SE 2P6S, HV48100 SE Lite 2P6S: 273 V HV48100 SE 2P7S, HV48100 SE Lite 2P7S: 318.5 V or any cell reaches 2.8 V
Operating temperature range	-20 °C to 50 °C
Standard charging method specified by manufacturer	Charge at constant current 50 A until voltage reaches HV48100 SE 1P3S, HV48100 SE Lite 1P3S: 168 V HV48100 SE 1P4S, HV48100 SE Lite 1P4S: 224 V HV48100 SE 1P5S, HV48100 SE Lite 1P5S: 280 V HV48100 SE 1P6S, HV48100 SE Lite 1P6S: 336 V HV48100 SE 1P7S, HV48100 SE Lite 1P7S: 392 V HV48100 SE 1P8S, HV48100 SE Lite 1P8S: 448 V HV48100 SE 1P9S, HV48100 SE Lite 1P9S: 504 V



	HV48100 SE 1P10S, HV48100 SE Lite 1P10S: 560 V HV48100 SE 1P11S, HV48100 SE Lite 1P11S: 616 V HV48100 SE 1P12S, HV48100 SE Lite 1P12S: 672 V HV48100 SE 1P13S, HV48100 SE Lite 1P13S: 728 V HV48100 SE 1P14S, HV48100 SE Lite 1P14S: 784 V HV48100 SE 1P15S, HV48100 SE Lite 1P15S: 840 V HV48100 SE 2P3S, HV48100 SE Lite 2P3S: 168 V HV48100 SE 2P4S, HV48100 SE Lite 2P4S: 224 V HV48100 SE 2P5S, HV48100 SE Lite 2P5S: 280 V HV48100 SE 2P6S, HV48100 SE Lite 2P6S: 336 V HV48100 SE 2P7S, HV48100 SE Lite 2P7S: 392 V then charge at constant voltage till charge current drops to 5 A or any cell reaches 3.55 V.
Standard discharging method specified by manufacturer	Discharge at constant current 50 A until voltage reaches HV48100 SE 1P3S, HV48100 SE Lite 1P3S: 136.6 V HV48100 SE 1P4S, HV48100 SE Lite 1P4S: 182 V HV48100 SE 1P5S, HV48100 SE Lite 1P5S: 227.5 V HV48100 SE 1P6S, HV48100 SE Lite 1P6S: 273 V HV48100 SE 1P7S, HV48100 SE Lite 1P7S: 318.5 V HV48100 SE 1P8S, HV48100 SE Lite 1P8S: 364 V HV48100 SE 1P9S, HV48100 SE Lite 1P9S: 409.5 V HV48100 SE 1P10S, HV48100 SE Lite 1P10S: 455 V HV48100 SE 1P11S, HV48100 SE Lite 1P11S: 500.5 V HV48100 SE 1P12S, HV48100 SE Lite 1P12S: 546 V HV48100 SE 1P13S, HV48100 SE Lite 1P13S: 591.5 V HV48100 SE 1P14S, HV48100 SE Lite 1P14S: 637 V HV48100 SE 1P15S, HV48100 SE Lite 1P15S: 682.5 V HV48100 SE 2P3S, HV48100 SE Lite 2P3S: 136.6 V HV48100 SE 2P4S, HV48100 SE Lite 2P4S: 182 V HV48100 SE 2P5S, HV48100 SE Lite 2P5S: 227.5 V HV48100 SE 2P6S, HV48100 SE Lite 2P6S: 273 V HV48100 SE 2P7S, HV48100 SE Lite 2P7S: 318.5 V or any cell reaches 2.8 V.
Dimension	LxWxH: Approx.: 1100 mm x1193 mm x 2015 mm



Weight	HV48100 SE 1P3S:	Approx. 580 kg
	HV48100 SE 1P4S:	Approx. 627 kg
	HV48100 SE 1P5S:	Approx. 674 kg
	HV48100 SE 1P6S:	Approx. 720 kg
	HV48100 SE 1P7S:	Approx. 767 kg
	HV48100 SE 1P8S:	Approx. 813 kg
	HV48100 SE 1P9S:	Approx. 860 kg
	HV48100 SE 1P10S:	Approx. 906 kg
	HV48100 SE 1P11S:	Approx. 953 kg
	HV48100 SE 1P12S:	Approx. 999 kg
	HV48100 SE 1P13S:	Approx. 1046 kg
	HV48100 SE 1P14S:	Approx. 1092 kg
	HV48100 SE 1P15S:	Approx. 1139 kg
	HV48100 SE 2P3S:	Approx. 734 kg
	HV48100 SE 2P4S:	Approx. 827 kg
	HV48100 SE 2P5S:	Approx. 920 kg
	HV48100 SE 2P6S:	Approx. 1013 kg
	HV48100 SE 2P7S:	Approx. 1106 kg
	HV48100 SE Lite 1P3S:	Approx. 553 kg
	HV48100 SE Lite 1P4S:	Approx. 600 kg
	HV48100 SE Lite 1P5S:	Approx. 647 kg
	HV48100 SE Lite 1P6S:	Approx. 693 kg
	HV48100 SE Lite 1P7S:	Approx. 740 kg
	HV48100 SE Lite 1P8S:	Approx. 786 kg
	HV48100 SE Lite 1P9S:	Approx. 833 kg
	HV48100 SE Lite 1P10S:	Approx. 879 kg
	HV48100 SE Lite 1P11S:	Approx. 926 kg
	HV48100 SE Lite 1P12S:	Approx. 972 kg
	HV48100 SE Lite 1P13S:	Approx. 1019 kg
	HV48100 SE Lite 1P14S:	Approx. 1065 kg
	HV48100 SE Lite 1P15S:	Approx. 1112 kg
	HV48100 SE Lite 2P3S:	Approx. 707 kg
HV48100 SE Lite 2P4S:	Approx. 800 kg	
HV48100 SE Lite 2P5S:	Approx. 893 kg	
HV48100 SE Lite 2P6S:	Approx. 986 kg	
HV48100 SE Lite 2P7S:	Approx. 1079 kg	



Configuration	HV48100 SE 1P3S,	HV48100 SE Lite 1P3S:	((8S)2S)3S
	HV48100 SE 1P4S,	HV48100 SE Lite 1P4S:	((8S)2S)4S
	HV48100 SE 1P5S,	HV48100 SE Lite 1P5S:	((8S)2S)5S
	HV48100 SE 1P6S,	HV48100 SE Lite 1P6S:	((8S)2S)6S
	HV48100 SE 1P7S,	HV48100 SE Lite 1P7S:	((8S)2S)7S
	HV48100 SE 1P8S,	HV48100 SE Lite 1P8S:	((8S)2S)8S
	HV48100 SE 1P9S,	HV48100 SE Lite 1P9S:	((8S)2S)9S
	HV48100 SE 1P10S,	HV48100 SE Lite 1P10S:	((8S)2S)10S
	HV48100 SE 1P11S,	HV48100 SE Lite 1P11S:	((8S)2S)11S
	HV48100 SE 1P12S,	HV48100 SE Lite 1P12S:	((8S)2S)12S
	HV48100 SE 1P13S,	HV48100 SE Lite 1P13S:	((8S)2S)13S
	HV48100 SE 1P14S,	HV48100 SE Lite 1P14S:	((8S)2S)14S
	HV48100 SE 1P15S,	HV48100 SE Lite 1P15S:	((8S)2S)15S
	HV48100 SE 2P3S,	HV48100 SE Lite 2P3S:	((8S)2S)3S ((8S)2S)3S
	HV48100 SE 2P4S,	HV48100 SE Lite 2P4S:	((8S)2S)4S ((8S)2S)4S

Remark:
 The models: HV48100 SE 2P3S and HV48100 SE Lite 2P3S, HV48100 SE 2P4S and HV48100 SE Lite 2P4S, HV48100 SE 2P5S and HV48100 SE Lite 2P5S, HV48100 SE 2P6S and HV48100 SE Lite 2P6S, HV48100 SE 2P7S and HV48100 SE Lite 2P7S each incorporate two independent battery systems, models: HV48100 SE BMU-3, HV48100 SE BMU-4, HV48100 SE BMU-5, HV48100 SE BMU-6 and HV48100 SE BMU-7.
 (The two battery systems, HV48100 SE BMU-3, HV48100 SE BMU-4, HV48100 SE BMU-5, HV48100 SE BMU-6 and HV48100 SE BMU-7, connected in parallel via a combiner box or PCS outside the battery cabinet, while the two battery systems inside the battery remain independent without mutual interference.)
 The test was conducted using the configuration with 1P15S inside the battery cabinet. This configuration features the maximum number of modules among all models and is subject to the most stringent requirements for thermal runaway testing, hence its selection for the test.

Attachments:
Attachment 1: Product description
Attachment 2: Exploded-view drawing of module & Identification/location of cells within the module
Attachment 3: Pre-conditioning profile



Test Report - ANSI/CAN/UL 9540A:2019 – Unit level

- Attachment 4: Photo of sample before test and test setup with thermocouple location
- Attachment 5: Photo of sample after test
- Attachment 6: Monitored temperature chart
- Attachment 7: Flammable gas generation and composition data chart
- Attachment 8: Heat release rate versus time data chart
- Attachment 9: Peak smoke release rate and total smoke release data chart
- Attachment 10: Summary of Heat release rate & Peak smoke release rate and total smoke release data

If additional information is necessary, please provide
 A battery system representative of a BESS was tested, model: HV48100 SE 1P15S

Copy of marking plate:

Series: HV48100 SE:

Pytes
 Product Model: HV48100 SE Battery Cabinet

Battery Module	<input type="checkbox"/> 2P5S	<input type="checkbox"/> 2P6S	<input type="checkbox"/> 2P7S	<input type="checkbox"/> 1P5S	<input type="checkbox"/> 1P6S	<input type="checkbox"/> 1P7S	<input type="checkbox"/> 1P8S	<input type="checkbox"/> 1P9S	<input type="checkbox"/> 1P10S	<input type="checkbox"/> 1P11S	<input type="checkbox"/> 1P12S	<input type="checkbox"/> 1P13S	<input type="checkbox"/> 1P14S	<input type="checkbox"/> 1P15S
Rated Energy	51.20kWh	61.44kWh	71.68kWh	25.60kWh	30.72kWh	35.84kWh	40.96kWh	46.08kWh	51.20kWh	56.32kWh	61.44kWh	66.56kWh	71.68kWh	76.80kWh
Nominal Voltage	256V	307.2V	358.4V	256V	307.2V	358.4V	409.6V	460.8V	512V	563.2V	614.4V	665.6V	716.8V	768V
Rated Power	25.60kW	30.72kW	35.84kW	12.80kW	15.36kW	17.92kW	20.48kW	23.04kW	25.60kW	28.16kW	30.72kW	33.28kW	35.84kW	38.40kW
Operating Voltage	237.5V~288V	285V~345.6V	332.5V~403.2V	237.5V~288V	285V~345.6V	332.5V~403.2V	380V~460.8V	427.5V~518.4V	475V~576V	522.5V~633.6V	570V~691.2V	617.5V~748.8V	665V~806.4V	712V~864V
Charge/Discharge Current	50A × 2			50A										
Rated Capacity	100Ah × 2			100Ah										
Max. # Cabinet per Inverter	3			6										
Dimensions (W x D x H)	43 × 47 × 79inch (1100 × 1193 × 2015mm)													
Weight (lb / kg)	2029 / 920	2234 / 1013	2439 / 1106	1486 / 674	1587 / 720	1691 / 767	1792 / 813	1896 / 860	1997 / 906	2101 / 953	2203 / 999	2306 / 1046	2408 / 1092	2511 / 1139
Operating Temperature	-4°F~122°F (-20°C~50°C)													
Ingress Rating	IP 55													
Operating Altitude	≤ 9843 ft (3000m)													
Relative Humidity	0~95% non-condensing													

S/N:

Date:

MADE IN CHINA
 Shanghai PYTES Energy Co., Ltd.
 No.3492, Jinqian Road, Fengxian
 District, Shanghai, 201406, China
www.pytesess.com
ess_support@pytesgroup.com

Pytes
 Product Model: HV48100 SE Battery Cabinet

Battery Module	<input type="checkbox"/> 2P3S	<input type="checkbox"/> 2P4S	<input type="checkbox"/> 1P3S	<input type="checkbox"/> 1P4S
Rated Energy	30.72kWh	40.96kWh	15.36kWh	20.48kWh
Nominal Voltage	153.6V	204.8V	153.6V	204.8V
Rated Power	15.36kW	20.48kW	7.68kW	10.24kW
Operating Voltage	142.5V~172.8V	190V~230.4V	142.5V~172.8V	190V~230.4V
Charge/Discharge Current	50A × 2		50A	
Rated Capacity	100Ah × 2		100Ah	
Max. # Cabinet per Inverter	3		6	
Dimensions (W x D x H)	43 × 47 × 79inch (1100 × 1193 × 2015mm)			
Weight (lb / kg)	1618 / 734	1823 / 827	1279 / 580	1382 / 627
Operating Temperature	-4°F~122°F (-20°C~50°C)			
Ingress Rating	IP 55			
Operating Altitude	≤ 9843 ft (3000m)			
Relative Humidity	0~95% non-condensing			

S/N:

Date:

MADE IN CHINA
 Shanghai PYTES Energy Co., Ltd.
 No.3492, Jinqian Road, Fengxian
 District, Shanghai, 201406, China
www.pytesess.com
ess_support@pytesgroup.com



Test Report - ANSI/CAN/UL 9540A:2019 – Unit level

Series: HV48100 SE Lite:

Pytes
Product Model: HV48100 SE Lite Battery Cabinet

Battery Module	<input type="checkbox"/> 2P5S	<input type="checkbox"/> 2P6S	<input type="checkbox"/> 2P7S	<input type="checkbox"/> 1P5S	<input type="checkbox"/> 1P6S	<input type="checkbox"/> 1P7S	<input type="checkbox"/> 1P8S	<input type="checkbox"/> 1P9S	<input type="checkbox"/> 1P10S	<input type="checkbox"/> 1P11S	<input type="checkbox"/> 1P12S	<input type="checkbox"/> 1P13S	<input type="checkbox"/> 1P14S	<input type="checkbox"/> 1P15S
Rated Energy	51.20kWh	61.44kWh	71.68kWh	25.60kWh	30.72kWh	35.84kWh	40.96kWh	46.08kWh	51.20kWh	56.32kWh	61.44kWh	66.56kWh	71.68kWh	76.80kWh
Nominal Voltage	256V	307.2V	358.4V	256V	307.2V	358.4V	409.6V	460.8V	512V	563.2V	614.4V	665.6V	716.8V	768V
Rated Power	25.60kW	30.72kW	35.84kW	12.80kW	15.36kW	17.92kW	20.48kW	23.04kW	25.60kW	28.16kW	30.72kW	33.28kW	35.84kW	38.40kW
Operating Voltage	237.5V~288V	285V~345.6V	332.5V~403.2V	237.5V~288V	285V~345.6V	332.5V~403.2V	380V~460.8V	427.5V~518.4V	475V~576V	522.5V~633.6V	570V~691.2V	617.5V~748.8V	665V~806.4V	712V~864V
Charge/Discharge Current	50A × 2							50A						
Rated Capacity	100Ah × 2							100Ah						
Max. # Cabinet per Inverter	3							6						
Dimensions (W x D x H)	43 × 47 × 79inch (1100 × 1193 × 2015mm)													
Weight (lb / kg)	1969 / 893	2174 / 986	2379 / 1079	1426 / 647	1528 / 693	1631 / 740	1733 / 786	1836 / 833	1938 / 879	2041 / 926	2143 / 972	2247 / 1019	2348 / 1065	2452 / 1112
Operating Temperature	-4°F~122°F (-20°C~50°C)													
Ingress Rating	IP 55													
Operating Altitude	≤ 9843 ft (3000m)													
Relative Humidity	0~95% non-condensing													

⚠ ⚠

S/N:

Date:

MADE IN CHINA
Shanghai PYTES Energy Co., Ltd.
No.3492, Jinqian Road, Fengxian District, Shanghai, 201406, China
www.pytesess.com
ess_support@pytesgroup.com

Pytes
Product Model: HV48100 SE Lite Battery Cabinet

Battery Module	<input type="checkbox"/> 2P3S	<input type="checkbox"/> 2P4S	<input type="checkbox"/> 1P3S	<input type="checkbox"/> 1P4S
Rated Energy	30.72kWh	40.96kWh	15.36kWh	20.48kWh
Nominal Voltage	153.6V	204.8V	153.6V	204.8V
Rated Power	15.36kW	20.48kW	7.68kW	10.24kW
Operating Voltage	142.5V~172.8V	190V~230.4V	142.5V~172.8V	190V~230.4V
Charge/Discharge Current	50A × 2		50A	
Rated Capacity	100Ah × 2		100Ah	
Max. # Cabinet per Inverter	3		6	
Dimensions (W x D x H)	43 × 47 × 79inch (1100 × 1193 × 2015mm)			
Weight (lb / kg)	1559 / 707	1764 / 800	1219 / 553	1323 / 600
Operating Temperature	-4°F~122°F (-20°C~50°C)			
Ingress Rating	IP 55			
Operating Altitude	≤ 9843 ft (3000m)			
Relative Humidity	0~95% non-condensing			

⚠ ⚠

S/N:

Date:

MADE IN CHINA
Shanghai PYTES Energy Co., Ltd.
No.3492, Jinqian Road, Fengxian District, Shanghai, 201406, China
www.pytesess.com
ess_support@pytesgroup.com

For S/N and Date

S/N: Date:

Remark:

- The S/N code can be used to trace the manufacture information of the battery. “+” and “-” are marked near the connector of the battery.
- “2025-Mar-4” represents the date of manufacture, meaning the battery was produced on Mar 4th, 2025. This is not the manufacture date of actual samples and only for example.
- Polarity “+” and “-” are marked near the connector of the battery.

Description and pictures of the tested product:

The battery cabinet, model: HV48100 SE 1P15S incorporates one built-in Rechargeable Li-ion Battery System, model: HV48100 SE BMU-15, which consists of 15 Rechargeable Li-ion Battery modules (model: HV48100 SE BMU) connected in series with the HV box (model: HV48100 SE BCU), is used for residential & non-residential applications, both for indoor & outdoor use.

The Rechargeable Li-ion Battery module, model: HV48100 SE BMU consists of Rechargeable Li-ion cells, model no., connected in (8S)2S.



Front view



Internal side view when the door is opened



UNIT LEVEL	
Summary of unit level testing:	
Unit model name	HV48100 SE 1P15S
Ratings	768 Vd.c., 100 Ah
Whether UL 1973 compliant	<p>Battery cabinet (model: HV48100 SE 1P15S) is not tested (or certified or verified) with UL 1973.</p> <p>The battery cabinet HV48100 SE series is composed of battery systems.</p> <p>Battery Systems, models: HV48100 SE BMU-3, HV48100 SE BMU-4, HV48100 SE BMU-5, HV48100 SE BMU-6, HV48100 SE BMU-7, HV48100 SE BMU-8, HV48100 SE BMU-9, HV48100 SE BMU-10, HV48100 SEBMU-11, HV48100 SE BMU-12, HV48100 SE BMU-13, HV48100 SE BMU-14, HV48100 SE BMU-15 respectively consist of 3, 4, 5, 6, 7, 8, 9, 10, 11, 12, 13, 14, 15 Rechargeable Li-ion Battery Modules (model: HV48100 SE BMU) connected in series with the HV box (model: HV48100 SE BCU) are compliant with UL 1973 Report No.: 64.280.25.60508.01 Certificate No.: U10 003364 0023 Rev. 01</p>
Number of modules in the initiating BESS unit	15
The construction of the initiating BESS unit per 5.3	See Attachment 1
Fire protection features/detection/suppression systems within unit	<p>HV48100 SE series is equipped with an integrated fire protection system (powered externally).</p> <p>HV48100 SE Lite series omits the fire protection system from its cabinet.</p> <p>Fire and detection system within unit, but inactive during test.</p>
Module voltage(s) corresponding to the tested SOC	See Table 1

UNIT LEVEL	
The thermal runaway initiation method used	Heating the cell with externally applied 2 pieces flexible film heaters that cover each large surface of the cell. Film heater specification: 101.6 mm × 127.0 mm (220 V, 250 W/pc)
Location of the initiating module within the BESS unit	See Attachment 4
Diagram and dimensions of the test setup including mounting location of the initiating and target BESS units, and the locations of walls, ceilings, and soffits	See Attachment 4
Observation of any flaming outside the initiating BESS enclosure and the maximum flame extension	No flaming outside the initiating BESS enclosure observed.
Chemical and convective heat release rate versus time data	See Attachment 8, 10
Separation distances from the initiating BESS unit to target walls (e. g. distances A and C in Figure 9.1)	See Attachment 4
Separation distances from the initiating BESS unit to target BESS units (e.g. distances D and H in Figure 9.1);	See Attachment 4
The maximum wall surface and target BESS temperatures achieved during the test and the location of the measuring thermocouple	See Table 3 and Attachment 4 and 6
The maximum ceiling or soffit surface temperatures achieved during the indoor or outdoor wall mounted test and the location of the measuring thermocouple	N/A
The maximum incident heat flux on target wall surfaces and target BESS units	Target wall surfaces: 0.07 kW/m ² Target BESS unit: 0.08 kW/m ²
The maximum incident heat flux on target ceiling or soffit surfaces achieved during the indoor or outdoor wall mounted test	N/A
Gas generation and composition data	See Table 2 and Attachment 7
Peak smoke release rate and total smoke release data	See Attachment 9, 10
Indication of the activation of integral fire protection systems and if activated the time into the test at which activation occurred	HV48100 SE series is equipped with an integrated fire protection system (powered externally). HV48100 SE Lite series omits the fire protection system from its cabinet. Fire and detection system within unit, but inactive during test.
Observation of flying debris or explosive discharge of gases	No observation of flying debris or explosive discharge of gases
Observation of re-ignition(s) from thermal runaway events	N/A (no fire during test)
Observation(s) of sparks, electrical arcs, or other electrical events	No observation of sparks, electrical arcs, or other electrical events



UNIT LEVEL	
Observations of the damage to: 1) The initiating BESS unit; 2) Target BESS units; 3) Adjacent walls, ceilings, or soffits;	1) Thermal runaway was observed on all 8 cells in the same row as the initiating cell of the Initiating module; No propagation to other modules of initiating unit; 2) No propagation to target units and no damage to target units; 3) No damage to adjacent walls, ceilings, or soffits; see Attachment 5
Performance at unit level testing:	
<input checked="" type="checkbox"/> Non-Residential Installations: <input checked="" type="checkbox"/> Residential Installations: <input checked="" type="checkbox"/> Indoor Floor Mounted <input checked="" type="checkbox"/> Outdoor Ground Mounted <input type="checkbox"/> Indoor Wall Mounted <input type="checkbox"/> Outdoor Wall Mounted <input type="checkbox"/> Rooftop and Open Garages	
a) Flaming outside the initiating BESS unit is not observed; (for Indoor Floor Mounted & Indoor Wall Mounted & Outdoor Wall Mounted)	No flaming outside the initiating BESS unit during test.
a) If flaming outside of the unit is observed, separation distances to exposures shall be determined by greatest flame extension observed during test. (for Outdoor Ground Mounted & Rooftop and Open Garages)	No flaming outside the initiating BESS unit during test.
b) Surface temperatures of modules within the target BESS units adjacent to the initiating BESS unit do not exceed the temperature at which thermally initiated cell venting occurs, as determined in 7.3.1.8;	Maximum temperature of target modules within the target BESS units adjacent to the initiating BESS unit: 32.3 °C.
c) For BESS units intended for installation in locations with combustible constructions, surface temperature measurements on wall surfaces do not exceed 97K of temperature rise above ambient per 9.2.15; (for Indoor Floor Mounted & Indoor Wall Mounted & Rooftop and Open Garages)	Maximum temperature of wall surface: 32.5 °C.
c) For BESS units intended for installation near exposures, surface temperature measurements on wall surfaces do not exceed 97K of temperature rise above ambient per 9.2.15; (for Outdoor Ground Mounted)	Maximum temperature of wall surface: 32.5 °C
d) Explosion hazards are not observed, including deflagration, detonation or accumulation (to within the	No explosion hazards were observed.



UNIT LEVEL	
flammability limits in an amount that can cause a deflagration) of battery vent gases; and	
e) Heat flux in the center of the accessible means of egress shall not exceed 1.3 kW/m ² .	0.08 kW/m ²
e) The concentration of flammable gas does not exceed 25% LFL in air for the smallest specified room installation size. (for Indoor Floor Mounted)	Volume of flammable gas measured during this test: 284.73 L. LFL from cell level test report: 5.95 % at the venting temperature. (External report with Project No. 4790342745) Resulting minimum room size: 19.15 m ³ to not exceed 25% LFL in air, at venting temperature.
Performance - module level test:	
a) Thermal runaway is contained by module design; and	Thermal runaway was contained by module design.
b) Cell vent gas is non-flammable as determined by the cell level test.	Cell vent gas is flammable according to cell level test report (external report with Project No. 4790342745).
Performance - cell level test:	
a) Thermal runaway cannot be induced in the cell; and	Thermal runaway occurred according to cell level test report (external report with Project No. 4790342745).
b) The cell vent gas does not present a flammability hazard when mixed with any volume of air, as determined in accordance with ASTM E918 at both ambient and vent temperatures.	Cell vent gas present flammability hazard according to cell level test report (external report with Project No. 4790342745).

Additional information on non-standard test method(s)	
Sub clause:	N/A
Page:	N/A
Rational:	N/A

Possible test case verdicts:	
test case does not apply to the test object:	N/A (not applicable / not included in the order)
test object does meet the requirement:	P (Pass)
test object does not meet the requirement:	F (Fail)



UNIT LEVEL	
General remarks:	
<i>"(see remark #)" refers to a remark appended to the report.</i>	
<i>"(see appended table)" refers to a table appended to the report.</i>	
<i>Throughout this report a <input type="checkbox"/> Comma / <input checked="" type="checkbox"/> Point is used as the decimal separator.</i>	
<i>The test results presented in this report relate only to the object tested.</i>	
<i>This report shall not be reproduced except in full without the written approval of the testing laboratory.</i>	

INTRODUCTION

1.	Scope	—
2	Units of Measurement	—
3	Normative References	—
4	Glossary	—

CONSTRUCTION

5.	General		
5.1	Cell		
5.1.1	The cells associated with the BESS that were tested shall be documented in the test report, including cell chemistry (e.g. NMC, LFP), the physical format of the cell (i.e. prismatic, cylindrical, pouch), cell electrical rating in capacity and nominal voltage, the overall dimensions of the cell, and weight.	Cell chemistry: LFP Physical cell format: Prismatic	P
5.1.2	The cell documentation included in the test report shall indicate if the cells associated with the BESS comply with UL 1973.	Cell certified by UL1973:2022 Cert. No.: UL-US-2236692-0 Report No.: 4790340175	P
5.1.3	Refer to 7.6.1 for further details to be included in the cell level test report		P
5.2	Module		
5.2.1	The modules associated with the BESS that were tested shall be documented in the test report, including the generic (e. g., metallic or nonmetallic) enclosure material, the general layout of the module contents and the electrical configuration of the cells in the modules and the modules in the BESS.	Module consists of a metallic enclosure material. Further details of the layout and module contents see Attachment 2.	P



UNIT LEVEL			
5.2.2	The module documentation included in the test report shall indicate if the modules associated with the BESS comply with UL 1973.	<p>Battery cabinet (model: HV48100 SE 1P15S) is not tested (or certified or verified) with UL 1973.</p> <p>The battery cabinet HV48100 SE series is composed of battery systems.</p> <p>Battery Systems, models: HV48100 SE BMU-3, HV48100 SE BMU-4, HV48100 SE BMU-5, HV48100 SE BMU-6, HV48100 SE BMU-7, HV48100 SE BMU-8, HV48100 SE BMU-9, HV48100 SE BMU-10, HV48100 SEBMU-11, HV48100 SE BMU-12, HV48100 SE BMU-13, HV48100 SE BMU-14, HV48100 SE BMU-15 respectively consist of 3, 4, 5, 6, 7, 8, 9, 10, 11, 12, 13, 14, 15 Rechargeable Li-ion Battery Modules (model: HV48100 SE BMU) connected in series with the HV box (model: HV48100 SE BCU) are compliant with UL 1973</p> <p>Report No.: 64.280.25.60508.01</p> <p>Certificate No.: U10 003364 0023 Rev. 01</p>	N/A
5.2.3	Refer to 8.3 for further details to be included in the module level test report.		P
5.3	Battery energy storage system unit		
5.3.1	The BESS unit documentation included in the test report shall indicate the units that comply with UL 9540 and include the manufacturer, model, electrical ratings, and energy capacity of all BESS.	<p>Unit manufacturer name: Shanghai PYTES Energy Co., Ltd.</p> <p>Model: HV48100 SE 1P15S; Rated capacity: 100 Ah</p>	N/A



UNIT LEVEL			
		Unit is not tested or certified or verified with UL 9540.	
5.3.2	For BESS units for which UL 9540 compliance cannot be determined, the documentation included in the test report shall include the number of modules in the BESS, electrical configuration of the module, and physical layout of the modules in the BESS, battery management system (BMS) and other major components of the BESS. The BESS enclosure overall dimensions and generic (e. g., metallic or nonmetallic) material used for the enclosure shall be documented. Depending upon the configuration of the BESS (e.g. the power conditioning system is external to the BESS enclosure), a battery system(s) can be tested as representative of the BESS. It shall be documented as to whether the battery system complies with UL 1973 in addition to the overall BESS compliance to UL 9540.	<p>Battery cabinet (model: HV48100 SE 1P15S) is not tested (or certified or verified) with UL 9540 and UL 1973.</p> <p>The battery cabinet HV48100 SE series is composed of battery systems.</p> <p>Battery Systems, models: HV48100 SE BMU-3, HV48100 SE BMU-4, HV48100 SE BMU-5, HV48100 SE BMU-6, HV48100 SE BMU-7, HV48100 SE BMU-8, HV48100 SE BMU-9, HV48100 SE BMU-10, HV48100 SEBMU-11, HV48100 SE BMU-12, HV48100 SE BMU-13, HV48100 SE BMU-14, HV48100 SE BMU-15 respectively consist of 3, 4, 5, 6, 7, 8, 9, 10, 11, 12, 13, 14, 15 Rechargeable Li-ion Battery Modules (model: HV48100 SE BMU) connected in series with the HV box (model: HV48100 SE BCU) are compliant with UL 1973</p> <p>Report No.: 64.280.25.60508.01 Certificate No.: U10 003364 0023 Rev. 01</p>	N/A
5.3.3	If applicable, the details of any fire detection and suppression systems that are an integral part of the BESS shall be noted in the test report.	<p>HV48100 SE series is equipped with an integrated fire protection system (powered externally).</p> <p>HV48100 SE Lite series omits the fire protection system from its cabinet.</p>	N/A



UNIT LEVEL			
		Since the fire suppression system inside the battery cabinet is powered externally, detection and suppression system within unit, but inactive during this test.	
5.3.4	Refer to 9.7, 10.4 and 10.7 for further details to be included in the unit level and if applicable, installation level test reports.	9.7 considered.	N/A
5.4	Flow Batteries		

PERFORMANCE

6	General		
6.1	The tests in this standard are extreme abuse conditions conducted on electrochemical energy storage devices that can result in fires, explosions, smoke, off gassing of flammable and toxic materials, exposure to toxic and corrosive liquids, and potential exposure to hazardous voltages and electrical energy. See Annex B for recommended testing practices.		P
6.2	At the conclusion of testing, samples shall be discharged in accordance with the manufacturer's specifications. All samples shall be disposed of in accordance with local regulations.		P
7	Cell Level		
8	Module Level		
9	Unit Level		
9.1	Sample and test configuration		
9.1.1	The unit level test shall be conducted with BESS units installed as described in the manufacturer's instructions and this section. Test configurations include the following:		P
	a) Indoor floor mounted non-residential use BESS;		P
	b) Indoor floor mounted residential use BESS;		P
	c) Outdoor ground mounted non-residential use BESS;		P
	d) Outdoor ground mounted residential use BESS;		P
	e) Indoor wall mounted non-residential use BESS;		N/A



UNIT LEVEL			
	f) Indoor wall mounted residential use BESS;		N/A
	g) Outdoor wall mounted non-residential use BESS;		N/A
	h) Outdoor wall mounted residential use BESS; and		N/A
	i) Rooftop and open garage non-residential use BESS installations.		N/A
9.1.2	The unit level test requires one initiating BESS unit in which an internal fire condition in accordance with the module level test is initiated and target adjacent BESS units representative of an installation. Tests conducted for indoor floor mounted installations shall be considered representative of both indoor floor mounted and outdoor ground mounted installations with fire propagation hazards and separation distances between initiating and target units representative of the installation. Tests shall be conducted indoors with fire propagation hazards and separation distances between initiating and target units representative of the installation. The results of such tests shall be considered to also represent an outdoor installation. Examples of potential test configurations are shown in Figure 9.1, Figure 9.2, Figure 9.3, and Figure 9.4.		P
	<p>Exception: Testing can be conducted outdoors for outdoor only installations if there are the following controls and environmental conditions in place:</p> <ul style="list-style-type: none"> a) Wind screens are utilized with a maximum wind speed maintained at ≤ 12 mph; b) The temperature range is within 10°C to 40°C (50°F to 104°F); c) The humidity is $< 90\%$ RH; d) There is sufficient light to observe the testing; e) There is no precipitation during the testing; f) There is control of vegetation and combustibles in the test area to prevent any impact on the testing and to prevent inadvertent fire spread from the test area; and g) There are protection mechanisms in place to prevent inadvertent access by unauthorized persons in the test area and to prevent exposure of persons to any hazards as a result of testing. 		N/A
9.1.3	Depending upon the configuration and design of the BESS (e.g. the BESS is composed of multiple separate parts within separate enclosures), this testing to determine fire characterization can be done at the battery system level. The suitability of this approach shall be determined based upon the overall design of the BESS and an analysis of the battery		P



UNIT LEVEL			
	system as representative of the overall BESS for fire characterization concerns.		
9.1.4	The initiating BESS unit shall contain components representative of a BESS unit in a complete installation. Combustible components that interconnect the initiating and target BESS units shall be included.		P
9.1.5	Target BESS units shall include the outer cabinet (if part of the design), racking, module enclosures, and components that retain cells components. The target BESS unit module enclosures do not need to contain cells.		P
9.1.6	The initiating BESS unit shall be at the maximum operating state of charge (MOSOC), in accordance with the manufacturer's specifications, for conducting the tests in this standard. After charging and prior to testing, the initiating BESS shall rest for a maximum period of 8 h at room ambient.	See Attachment 3: Pre-conditioning profile. Charge at constant current 50A until the voltage reaches 840V, then charge at constant voltage 840V until current drops to 5A or any cells reach 3.55V.	P
9.1.7	If a BESS unit includes an integral fire suppression system, there is an option of providing this with the DUT. If the BESS unit is provided with an optional integral fire suppression system, the system shall not be provided on the DUT.	HV48100 SE series is equipped with an integrated fire protection system (powered externally). HV48100 SE Lite series omits the fire protection system from its cabinet. Since the fire suppression system inside the battery cabinet is powered externally, detection and suppression system within unit, but inactive during this test.	N/A
9.1.8	Electronics and software controls such as the battery management system (BMS) in the BESS are not relied upon for this testing. This does not include a fire suppression control in accordance with UL 840 that is external to the BESS, but provided as part of an integral fire suppression system per 9.1.7.		P
9.2	Test method – Indoor floor mounted BESS units		
9.2.1	Samples and test configurations are in accordance with 9.1. During the test, the test room environment shall be controlled to prevent drafts that may affect test results. At the start of the test, the room ambient		P



UNIT LEVEL			
	temperature shall not be less than 10°C (50°F) nor more than 32°C (90°F).		
9.2.2	Any access door(s) or panels on the initiating BESS unit and adjacent target BESS units shall be closed, latched and locked at the beginning and duration of the test.		P
9.2.3	The initiating BESS unit shall be positioned adjacent to two instrumented wall sections.		P
9.2.4	Instrumented wall sections shall extend not less than 0.49 m (1.6 ft) horizontally beyond the exterior of the target BESS units.		P
9.2.5	Instrumented wall sections shall be at least 0.61-m (2-ft) taller than the BESS unit height, but not less than 3.66 m (12 ft) in height above the bottom surface of the unit.		P
9.2.6	The surface of the instrumented wall sections shall be covered with 16-mm (5/8-in) gypsum wall board and painted flat black.		P
9.2.7	The initiating BESS unit shall be centered underneath an appropriately sized smoke collection hood of an oxygen consumption calorimeter.		P
9.2.8	The light transmission in the calorimeter's exhaust duct shall be measured using a white light source and photo detector for the duration of the test, and the smoke release rate shall be calculated as described in 8.2.15.		P
9.2.9	The chemical and convective heat release rates shall be measured for the duration of the test, using the methodologies specified in 8.2.11 and 9.2.12, respectively.		P
9.2.10	With reference to 9.2.9, the heat release rate measurement system shall be calibrated using an atomized heptane diffusion burner. The calibration shall be performed using flows of 3.8, 7.6, 11.4 and 15.2 L/min (1, 2, 3 and 4 gpm) of heptane.		P
9.2.11	With reference to 9.2.9, the convective heat release rate shall be measured using thermopile, a velocity probe, and a Type K thermocouple, located in the exhaust system of the exhaust duct. See 9.2.12.		P
9.2.12	With reference to 9.2.9, the convective heat release rate shall be calculated using the following equation: $HRR_c = V_e A \frac{353.22}{T_e} \int_{T_o}^T C_p dT$		P



UNIT LEVEL			
9.2.13	The physical spacing between BESS units (both initiating and target) and adjacent walls shall be representative of the intended installation as noted in 9.1.	See Attachment 4	P
9.2.14	Separation distances shall be specified by the manufacturer for distance between:		P
	a) The BESS units and the instrumented wall sections; and		P
	b) Adjacent BESS units.		P
9.2.15	Wall surface temperature measurements shall be collected for BESS intended for installation in locations with combustible construction. If the intended installation is composed completely of noncombustible construction in which wall assemblies, cables, wiring and any other combustible materials are not to be present in the BESS installation, then the report should note that the installation shall contain no combustible construction and that surface temperature rises can be deemed not applicable.		P
9.2.16	Wall surface temperatures shall be measured in vertical array(s) at 152-mm (6-in) intervals for the full height of the instrumented wall sections using No. 24-gauge or smaller, Type-K exposed junction thermocouples. The thermocouples for measuring the temperature on wall surfaces shall be horizontally positioned in the wall locations anticipated to receive the greatest thermal exposure from the initiating BESS unit.		P
9.2.17	Thermocouples shall be secured to gypsum surfaces by the use of staples placed over the insulated portion of the wires. The thermocouple tip shall be depressed into the gypsum so as to be flush with the gypsum surface at the point of measurement and held in thermal contact with the surface at that point by the use of pressure-sensitive paper tape.		P
9.2.18	Heat flux shall be measured with the sensing element of at least two water-cooled Schmidt-Boelter gauges at the surface of each instrumented wall: a) Both are collinear with the vertical thermocouple array; b) One is positioned at the elevation estimated to receive the greatest heat flux due to the thermal runaway of the initiating module; and c) One is positioned at the elevation estimated to receive the greatest heat flux during potential propagation of thermal runaway within the initiating BESS unit.		P



UNIT LEVEL			
9.2.19	Heat flux shall be measured with the sensing element of at least two water-cooled Schmidt-Boelter gauges at the surface of each adjacent target BESS unit that faces the initiating BESS unit: a) One is positioned at the elevation estimated to receive the greatest heat flux due to the thermal runaway of the initiating module within the initiating BESS; and b) One is positioned at the elevation estimated to receive the greatest surface heat flux due to the thermal runaway of the initiating BESS.		P
9.2.20	For non-residential use BESS, heat flux shall be measured with the sensing element of at least one water-cooled Schmidt-Boelter gauge positioned at the mid height of the initiating unit in the center of the accessible means of egress.		P
9.2.21	No. 24-gauge or smaller, Type-K exposed junction thermocouples shall be installed to measure the temperature of the surface proximate to the cells and between the cells and exposed face of the initiating module. Each non-initiating module enclosure within the initiating BESS unit shall be instrumented with at least one No. 24-gauge or smaller Type-K thermocouple(s) to provide data to monitor the thermal conditions within non-initiating modules. Additional thermocouples shall be placed to account for convoluted enclosure interior geometries.		P
9.2.22	For residential use BESS, the DUT shall be covered with a single layer of cheese cloth ignition indicator. The cheesecloth shall be untreated cotton cloth running 26 – 28 m ² /kg with a count of 28 – 32 threads in either direction within a 6.45 cm ² (1 in ²) area.		P
9.2.23	An internal fire condition in accordance with the module level test shall be created within a single module in the initiating BESS unit: a) The position of the module shall be selected to present the greatest thermal exposure to adjacent modules (e.g. above, below, laterally), based on the results from the module level test; and b) The setup (i.e. type, quantity and positioning) of equipment for initiating thermal runaway in the module shall be the same as that used to initiate and propagate thermal runaway within the module level test (Section 8).		P
9.2.24	The composition, velocity and temperature of the initiating BESS unit vent gases shall be measured within the calorimeter's exhaust duct. Gas composition shall be measured using a Fourier-Transform Infrared Spectrometer with a minimum resolution of 1 cm ⁻¹ and a path length of at least		P



UNIT LEVEL			
	2.0 m (6.6 ft), or equivalent gas analyzer. Composition, velocity and temperature instrumentation shall be collocated with heat release rate calorimetry instrumentation.		
9.2.25	The hydrocarbon content of the vent gas shall be measured using flame ionization detection.		P
9.2.26	The test shall be terminated if:		P
	a) Temperatures measured inside each module within the initiating BESS unit return to ambient temperature;		P
	b) The fire propagates to adjacent units or to adjacent walls; or		N/A
	c) A condition hazardous to test staff or the test facility requires mitigation.		N/A
9.2.27	For residential use systems, the gas collection data gathered in 9.2 shall be compared to the smallest room installation specified by the manufacturer to determine if the flammable gas collected exceeds 25% LFL in air.	Volume of flammable gas measured during this test: 284.73 L. LFL from cell level test report: 5.95 % at the venting temperature. (External report with Project No. 4790342745) Resulting minimum room size: 19.15 m ³ to not exceed 25% LFL in air, at venting temperature.	P
9.3	Test method – Outdoor ground mounted units		
9.3.1	Outdoor ground mounted non-residential use BESS being evaluated for installation in close proximity to buildings and structures shall use the test method described in Section 9.2. If intended for outdoor use only installations, the smoke release rate, the convective and chemical heat release rate and content, velocity and temperature of the released vent gases need not be measured.		P
9.3.2	Outdoor ground mounted residential use BESS being evaluated for installation in close proximity to buildings and structures shall use the test method described in Section 9.2 except as noted in 9.3.3 and 9.3.4. Heat flux measurements for the accessible means of egress shall be measured in accordance with 9.2.20. If intended for outdoor use only installations, the smoke release rate, the convective and chemical heat release rate and content, velocity and temperature of the released vent gases need not be measured.		P
9.3.3	Test samples shall be installed as shown in Figure 9.2 in proximity to an instrumented wall section that is		P

UNIT LEVEL			
	3.66-m (12-ft) tall with a 0.3-m (1-ft) wide horizontal soffit (undersurface of the eave shown in Figure 9.2). The sample shall be mounted on a support substrate and spaced from the wall in accordance with the minimum separation distances specified by the manufacturer. The wall and soffit shall be constructed with 19.05-mm (3/4-in) plywood installed on wood studs and painted flat black. The instrumented wall shall extend not less than 0.49-m (1.6-ft) horizontally beyond the exterior of the target BESS units. The No. 24-gauge or smaller, Type-K exposed junction thermocouple array on the walls as noted in 9.2.16 shall extend to the surface of the soffit as shown in Figure 9.2.		
	Exception: <i>If the manufacturer requires installation against non-flammable material, the test setup may include manufacturer recommended backing material between the unit and plywood wall.</i>		N/A
9.3.4	Target BESS shall be installed on each side of the initiating BESS in accordance with the manufacturer's installation specifications. The physical spacing between BESS units (both initiating and target) shall be the minimum separation distances specified by the manufacturer.		P
9.4	Test Method – Indoor wall mounted units		
9.5	Test Method – Outdoor wall mounted units		
9.6	Rooftop and open garage installations		
9.7	Unit level test report		
9.7.1	The report on the unit level testing shall identify the type of installation being tested, as follows:		P
	a) Indoor floor mounted non-residential use BESS;		P
	b) Indoor floor mounted residential use BESS;		P
	c) Outdoor ground mounted non-residential use BESS;		P
	d) Outdoor ground mounted residential use BESS;		P
	e) Indoor wall mounted non-residential use BESS;		N/A
	f) Indoor wall mounted residential use BESS;		N/A
	g) Outdoor wall mounted non-residential use BESS;		N/A
	h) Outdoor wall mounted residential use BESS;		N/A
	i) Rooftop installed non-residential use BESS; or		N/A



UNIT LEVEL			
	j) Open garage installed non-residential use BESS.		N/A
9.7.2	With reference to 9.7.1, if testing is intended to represent more than one installation type, this shall be noted in the report.	The testing is intended to represent the following types of BESS: 1. Indoor floor-mounted non-residential use BESS 2. Indoor floor-mounted residential use BESS 3. Outdoor ground-mounted non-residential use BESS 4. Outdoor ground-mounted residential use BESS	P
9.7.3	The report shall include the following, as applicable:		P
	a) Unit manufacturer name and model number (and whether UL 9540 compliant);	Unit manufacturer name: Shanghai PYTES Energy Co., Ltd. Model: HV48100 SE 1P15S Battery cabinet it is not tested or certified or verified with UL 9540.	N/A
	b) Number of modules in the initiating BESS unit;	15 modules	P
	c) The construction of the initiating BESS unit per 5.3;	See Attachment 1	P
	d) Fire protection features / detection / suppression systems within unit;	HV48100 SE series is equipped with an integrated fire protection system (powered externally). HV48100 SE Lite series omits the fire protection system from its cabinet. Since the fire suppression system inside the battery cabinet is powered externally, detection and suppression system within unit, but inactive during this test.	N/A
	e) Module voltage(s) corresponding to the tested SOC;	See Table 1	P
	f) The thermal runaway initiation method used;	See Table 1	P
	g) Location of the initiating module within the BESS unit;	See Attachment 4	P
	h) Diagram and dimensions of the test setup including mounting location of the initiating and target BESS units, and the locations of walls, ceilings, and soffits;	See Attachment 4	P



UNIT LEVEL			
	i) Observation of any flaming outside the initiating BESS enclosure and the maximum flame extension;	No flaming during the test	P
	j) Chemical and convective heat release rate versus time data;	See Attachment 8, 10	P
	k) Separation distances from the initiating BESS unit to target walls (e. g. distances A and C in Figure 9.1);	See Attachment 4	P
	l) Separation distances from the initiating BESS unit to target BESS units (e.g. distances D and H in Figure 9.1);	See Attachment 4	P
	m) The maximum wall surface and target BESS temperatures achieved during the test and the location of the measuring thermocouple;	See Table 3 and Attachment 4 and 6	P
	n) The maximum ceiling or soffit surface temperatures achieved during the indoor or outdoor wall mounted test and the location of the measuring thermocouple;	Testing is intended to represent Indoor floor mounted and Outdoor ground mounted.	N/A
	o) The maximum incident heat flux on target wall surfaces and target BESS units;	Target wall surfaces: 0.07kW/m ² Target BESS unit: 0.08kW/m ²	P
	p) The maximum incident heat flux on target ceiling or soffit surfaces achieved during the indoor or outdoor wall mounted test;		N/A
	q) Gas generation and composition data;	See Table 2 and Attachment 7	P
	r) Peak smoke release rate and total smoke release data;	See Attachment 9, 10	P
	s) Indication of the activation of integral fire protection systems and if activated the time into the test at which activation occurred;	HV48100 SE series is equipped with an integrated fire protection system (powered externally). HV48100 SE Lite series omits the fire protection system from its cabinet. Since the fire suppression system inside the battery cabinet is powered externally, detection and suppression system within unit, but inactive during this test.	N/A
	t) Observation of flying debris or explosive discharge of gases;	No observation of flying debris or explosive discharge of gases.	P
	u) Observation of re-ignition(s) from thermal runaway events;	No fire during test	N/A



UNIT LEVEL			
	v) Observation(s) of sparks, electrical arcs, or other electrical events;	No observation(s) of sparks, electrical arcs, or other electrical events.	P
	w) Observations of the damage to: 1) The initiating BESS unit; 2) Target BESS units; 3) Adjacent walls, ceilings, or soffits; and	see Attachment 5	P
	x) Photos and video of the test.		P
9.8	Performance at unit level testing		
9.8.1	Installation level testing in Section 10 is not required if the following performance conditions outlined in Table 9.1 are met during the unit level test.		P
Table 9.1	Unit Level Performance Criteria		
	Non-Residential Installations: Indoor Floor Mounted		P
	a) Flaming outside the initiating BESS unit is not observed;	No flaming outside the initiating BESS unit during test.	P
	b) Surface temperatures of modules within the target BESS units adjacent to the initiating BESS unit do not exceed the temperature at which thermally initiated cell venting occurs, as determined in 7.3.1.8;	Maximum temperature of target modules within the target BESS units adjacent to the initiating BESS unit: 32.3 °C.	P
	c) For BESS units intended for installation in locations with combustible constructions, surface temperature measurements on wall surfaces do not exceed 97K of temperature rise above ambient per 9.2.15;	Maximum temperature of wall surface: 32.5 °C.	P
	d) Explosion hazards are not observed, including deflagration, detonation or accumulation (to within the flammability limits in an amount that can cause a deflagration) of battery vent gases; and	Explosion hazards are not observed.	P
	e) Heat flux in the center of the accessible means of egress shall not exceed 1.3 kW/m ² .	0.08 kW/m ²	P
	Non-Residential Installations: Outdoor Ground Mounted		
	a) If flaming outside of the unit is observed, separation distances to exposures shall be determined by greatest flame extension observed during test.	No flaming outside the initiating BESS unit during test.	P
	b) Surface temperatures of modules within the target BESS units adjacent to the initiating BESS unit do not exceed the temperature at which thermally initiated cell venting occurs, as determined in 7.3.1.8;	Maximum temperature of target modules within the target BESS units adjacent to the initiating BESS unit: 32.3 °C	P



UNIT LEVEL			
	c) For BESS units intended for installation near exposures, surface temperature measurements on wall surfaces do not exceed 97K of temperature rise above ambient per 9.2.15;	Maximum temperature of wall surface: 32.5 °C	P
	d) Explosion hazards are not observed, including deflagration, detonation or accumulation (to within the flammability limits in an amount that can cause a deflagration) of battery vent gases; and	Explosion hazards are not observed.	P
	e) Heat flux in the center of the accessible means of egress shall not exceed 1.3 kW/m ² .	0.08 kW/m ²	P
	Non-Residential Installations: Indoor Wall Mounted		
	Non-Residential Installations: Outdoor Wall Mounted		
	Non-Residential Installations: Rooftop and Open Garages		
	Residential Installations: Indoor Floor Mounted		
	a) Flaming outside the initiating BESS unit is not observed as demonstrated by no flaming or charring of the cheesecloth indicator;	No flaming outside the initiating BESS unit during test.	P
	b) Surface temperatures of modules within the target BESS units adjacent to the initiating BESS unit do not exceed the temperature at which thermally initiated cell venting occurs, as determined in 7.3.1.8;	Maximum temperature of target modules within the target BESS units adjacent to the initiating BESS unit: 32.3 °C.	P
	c) For BESS units intended for installation in locations with combustible construction, surface temperature measurements on wall surfaces do not exceed 97K of temperature rise above ambient per 9.2.15;	Maximum temperature of wall surface: 32.5 °C.	P
	d) Explosion hazards are not observed, including deflagration, detonation or accumulation (to within the flammability limits in an amount that can cause a deflagration) of battery vent gases; and	Explosion hazards are not observed.	P
	e) The concentration of flammable gas does not exceed 25% LFL in air for the smallest specified room installation size.	Volume of flammable gas measured during this test: 284.73 L. LFL from cell level test report: 5.95 % at the venting temperature. (External report with Project No. 4790342745)	P



UNIT LEVEL			
		Resulting minimum room size: 19.15 m ³ to not exceed 25% LFL in air, at venting temperature.	
	Residential Installations: Outdoor Ground Mounted		
	a) If flaming outside the unit is observed, separation distances to exposures shall be determined by greatest flame extension observed during test.	No flaming outside the initiating BESS unit during test.	P
	b) Surface temperatures of modules within the target BESS units adjacent to the initiating BESS unit do not exceed the temperature at which thermally initiated cell venting occurs, as determined in 7.3.1.8;	Maximum temperature of target modules within the target BESS units adjacent to the initiating BESS unit: 32.3 °C.	P
	c) For BESS units intended for near exposures, surface temperature measurements on wall surfaces do not exceed 97K of temperature rise above ambient per 9.2.15;	Maximum temperature of wall surface: 32.5 °C.	P
	d) Explosion hazards are not observed, including deflagration, detonation or accumulation (to within the flammability limits in an amount that can cause a deflagration) of battery vent gases; and	Explosion hazards are not observed.	P
	e) Heat flux in the center of the accessible means of egress shall not exceed 1.3 kW/m ² .	0.08 kW/m ²	P
	Residential Installations: Indoor Wall Mounted		
	Residential Installations: Outdoor Wall Mounted		
10	Instalaton Level		—
ANNEX A	Test Concepts And Application Of Test Results To Installations (informative)		—
A1	Introduction		N/A
A2	Test Methodology and Purpose		N/A
A3	Evaluating the Results		N/A
ANNEX B	Safety Recommendations for Testing (informative)		—
B1	General		P



UNIT LEVEL



TABLE: Critical components information					
Object/part no.	Manufacturer/ trademark	Type/model	Technical data	Standard	Mark(s) of conformity
Lithium ion Cell	REPT BATTERO Energy Co., Ltd.		3.2 Vd.c., 100 Ah	ANSI/CAN/UL 1973: 2022	UL MH64238-20220923
Lithium ion Cell	REPT BATTERO Energy Co., Ltd.		3.2 Vd.c., 100 Ah	ANSI/CAN/UL 9540A: 2019	External report with project number 4790342745
Rechargeable Li-ion Battery	Shanghai PYTES Energy Co., Ltd.	HV48100 SE BMU	51.2 Vd.c., 100 Ah	ANSI/CAN/UL 9540A: 2019	Report No.: 5061925025 712-00
Supplementary information: N/A					







UNIT LEVEL

UNIT LEVEL TEST RESULT:



Table 1: Thermal runaway test result	
Summary of initiating module	
Initial ambient temperature:	28.3 °C
Initial relative humidity:	58% RH
Pre-conditioning time	From 2025-06-17 17:13:46 to 2025-06-18 09:55:40
Thermal runaway test start time	2025-06-18 17:12:56
Module voltage before test:	53.9 V
Methods used to initiate thermal runaway	Heating the cell with two externally applied flexible film heaters with 5.0 K/min heating rate until thermal runaway occurs.
Average heating rate:	T1: 5.0 K/min, T2: 5.0 K/min
Surface temperature when gases were first vented:	T4: 134.2 °C, T12: 212.4 °C, T13: 192.4 °C
Time when gases were first vented:	Cell 4: 2025-06-18 18:05:30
Surface temperature when thermal runaway:	T4: 167.9 °C, T9: 255.7 °C, T10: 256.5 °C
Time when thermal runaway:	Cell 4: 2025-06-18 18:24:40
Initiating Module voltage after test:	Module 4: 26.75 V
Location of cell(s) for initiating thermal runaway	Cell 4 (see Attachment 1)
Thermal runaway of other cells within module:	Thermal runaway was observed on all 8 cells in the same row as the initiating cell of the module.
Observation(s) of flying debris:	No
Observation(s) of explosive discharge of gas:	No
Observation(s) of sparks, electrical arcs or other electrical events:	No
Locations and visual estimations of flame	N/A, no flames observed.
Module weight before test:	46.1 kg
Module weight after test:	42.9 kg
Module weight loss:	3.2 kg
Summary of other modules	
Status of other modules	No thermal runaway observed
Supplementary information:	N/A

UNIT LEVEL		
Timeline of thermal runaway		
Time (hh:mm:ss)	Event	Description
2025-06-18 17:12:56	Start testing	
2025-06-18 18:05:30	The initiating cell 4 first vented.	
2025-06-18 18:23:22	The cell 5 vented.	

UNIT LEVEL		
<p>2025-06-18 18:24:40</p>	<p>Gas is observed from the bottom of the cabinet and the temperature of initiating cell 4 started to rise sharply, thermal runaway occurred.</p>	
<p>2025-06-18 18:25:12</p>	<p>The cell 3 vented.</p>	

UNIT LEVEL		
<p>2025-06-18 18:25:46</p>	<p>Gas is observed from the bottom of the cabinet and the temperature of cell 5 started to rise sharply, thermal runaway occurred.</p>	
<p>2025-06-18 18:26:26</p>	<p>Gas is observed from the bottom of the cabinet and the temperature of cell 3 started to rise sharply, thermal runaway occurred.</p>	

UNIT LEVEL		
		
2025-06-18 18:28:10	The cell 6 vented.	
2025-06-18 18:28:37	The cell 2 vented and gas is observed from the bottom of the cabinet and the temperature of cell 6 started to rise sharply, thermal runaway occurred.	

UNIT LEVEL		
		
<p>2025-06-18 18:31:11</p>	<p>Gas is observed from the bottom of the cabinet and the temperature of cell 2 started to rise sharply, thermal runaway occurred.</p>	 

UNIT LEVEL		
<p>2025-06-18 16:33:54</p>	<p>The cell 1 vented.</p>	
<p>2025-06-18 18:35:54</p>	<p>Gas is observed from the bottom of the cabinet and the temperature of cell 1 started to rise sharply, thermal runaway occurred.</p>	
<p>Remark: Refer to attachment 4 for details of sample before test and test setup with thermocouple location.</p>		



UNIT LEVEL

Table 2: Vent gas composition

Composition	Chemical formula	Measurement peak (L/min)	Analysis Method
Carbon monoxide	CO	0.9	NDIR
Carbon dioxide	CO ₂	44.1	NDIR
Methane	CH ₄	0.23	FTIR
Acetylene	C ₂ H ₂	/	FTIR
Ethene	C ₂ H ₄	/	FTIR
Ethane	C ₂ H ₆	0.048	FTIR
Propane	C ₃ H ₈	0.048	FTIR
Butane	C ₄ H ₁₀	/	FTIR
Pentane	C ₅ H ₁₂	/	FTIR
Benzene	C ₆ H ₆	/	FTIR
Hexane	C ₆ H ₁₄	/	FTIR
Hydrofluoric acid	HF	/	FTIR
Hydrogen chloride	HCl	/	FTIR
Hydrogen	H ₂	7.2	Hydrogen sensor
Total Hydrocarbons	(Methane Equivalent)	3.66	FID
Flow rate in exhaust duct (m ³ /s)			1.5



UNIT LEVEL

Table 3: Monitored temperature result

Number	Thermocouple location	Measured maximum temperature, °C	Limit, °C
T1	Center of side surface of cell 1	464.7	-
T2	Center of side surface of cell 2	490.5	-
T3	Center of side surface of cell 3	499.6	-
T4	Center of side surface of cell 4	503.9	-
T5	Center of side surface of cell 5	492.3	-
T6	Center of side surface of cell 6	468.9	-
T7	Center of side surface of cell 7	Broken	-
T8	Center of side surface of cell 8	Broken	-
T9	Center of side surface of cell 11	90.2	-
T10	Center of side surface of cell 12	90.7	-
T11	Center of side surface of cell 13	88.2	-
T12	Center of the film heater 1, between Cell 3 and Cell 4	651.4	-
T13	Center of the film heater 2, between Cell 4 and Cell 5	614.2	-
T001	Center of top surface of M04, Initiating Unit	91.3	-
T002	Center of bottom surface of M04, Initiating Unit	103.7	-
T003	Center of left surface of M04, Initiating Unit	184.8	-
T004	Center of right surface of M04, Initiating Unit	171.9	-
T005	Center of front surface of M04, Initiating Unit	269.3	-
T006	Center of rear surface of M04, Initiating Unit	158.0	-
T007	The closest point on the top cover to the initiating cell	399.2	-
T008	Center of top surface of M01	41.5	-
T009	Center of top surface of M02	42.5	-
T010	Center of top surface of M05	42.7	-
T011	Center of top surface of M06	43.9	-
T012	Center of top surface of M07	43.3	-
T013	Center of top surface of M010	39.0	-
T014	Center of top surface of M011	47.3	-
T015	Center of top surface of M012	45.4	-
T016	Center of top surface of M013	48.8	-
T017	Center of top surface of M014	38.8	-
T018	Center of top surface of M015	36.3	-
T019	Centre of the top at the rear door inside the cabinet, Target Unit 2	29.2	134.2



UNIT LEVEL			
T020	Centre of the mid-section at the rear door inside the cabinet, Target Unit 2	31.4	134.2
T021	Centre of the base at the rear door inside the cabinet, Target Unit 2	27.5	134.2
T022	At the top of the rear left corner inside the cabinet, Target Unit 3	30.9	134.2
T023	At the mid-section of the rear left corner inside the cabinet, Target Unit 3	30.1	134.2
T024	At the top of the rear left corner inside the cabinet, Target Unit 3, Target Unit 3	32.3	134.2
T025	Centre of the top at the interior left wall of the cabinet, Target Unit 1	30.8	134.2
T026	Centre of the mid-section at the interior left wall of the cabinet, Target Unit 1	30.6	134.2
T027	Centre of the base at the interior left wall of the cabinet, Target Unit 1	29.6	134.2
TA28	Front case - Initiating Unit	33.1	-
TA29	Back case - Initiating Unit	29.2	-
TA30	Left case - Initiating Unit	32.9	-
TA31	Right case - Initiating Unit	35.5	-
TA32	Top case - Initiating Unit	36.2	-
TA33	Bottom case - Initiating Unit	32.1	-
TA34	Front case - Target Unit 1	28.9	-
TA35	Back case - Target Unit 1	30.3	-
TA36	Left case - Target Unit 1	30.5	-
TA37	Right case - Target Unit 1	27.5	-
TA38	Top case -Target Unit 1	28.1	-
TA39	Bottom case - Target Unit 1	28.9	-
TA40	Front case - Target Unit 2	29.4	-
TA41	Back case - Target Unit 2	30.2	-
TA42	Left case - Target Unit 2	30.2	-
TA43	Right case - Target Unit 2	30.5	-
TA44	Top case -Target Unit 2	30.8	-
TA45	Bottom case - Target Unit 2	29.3	-
TA46	Front case - Target Unit 3	30.3	-
TA47	Back case - Target Unit 3	30.3	-
TA48	Left case - Target Unit 3	30.8	-
TA49	Right case - Target Unit 3	30.4	-



UNIT LEVEL			
-------------------	--	--	--

TA50	Top case -Target Unit 3	29.5	-
TA51	Bottom case - Target Unit 3	27.4	-
TWA1	Wall A surface 1	28.2	123
TWA2	Wall A surface 2	28.5	123
TWA3	Wall A surface 3	29.1	123
TWA4	Wall A surface 4	29.2	123
TWA5	Wall A surface 5	29.8	123
TWA6	Wall A surface 6	29.2	123
TWA7	Wall A surface 7	29.2	123
TWA8	Wall A surface 8	28.9	123
TWA9	Wall A surface 9	29.5	123
TWA10	Wall A surface 10	30.1	123
TWA11	Wall A surface 11	29.9	123
TWA12	Wall A surface 12	29.8	123
TWA13	Wall A surface 13	30.0	123
TWA14	Wall A surface 14	30.2	123
TWA15	Wall A surface 15	31.6	123
TWA16	Wall A surface 16	31.3	123
TWA17	Wall A surface 17	30.6	123
TWA18	Wall A surface 18	31.5	123
TWA19	Wall A surface 19	32.5	123
TWA20	Wall A surface 20	30.5	123
TWA21	Wall A surface 21	30.5	123
TWA22	Wall A surface 22	30.4	123
TWA23	Wall A surface 23	30.1	123
TWA24	Wall A surface 24	30.8	123
TWA25	Wall A additional 1, the same height of initiating module	28.7	123
TWA26	Wall A additional 2, the same height of initiating module	28.6	123
TWA27	Wall A additional 3, the same height of initiating module	29.0	123
TWB1	Wall B surface 1	29.5	123
TWB2	Wall B surface 2	30.0	123
TWB3	Wall B surface 3	29.9	123
TWB4	Wall B surface 4	29.6	123
TWB5	Wall B surface 5	29.3	123
TWB6	Wall B surface 6	29.4	123
TWB7	Wall B surface 7	30.2	123



UNIT LEVEL			
TWB8	Wall B surface 8	29.6	123
TWB9	Wall B surface 9	30.3	123
TWB10	Wall B surface 10	30.3	123
TWB11	Wall B surface 11	30.4	123
TWB12	Wall B surface 12	29.9	123
TWB13	Wall B surface 13	29.1	123
TWB14	Wall B surface 14	30.4	123
TWB15	Wall B surface 15	30.2	123
TWB16	Wall B surface 16	30.3	123
TWB17	Wall B surface 17	30.7	123
TWB18	Wall B surface 18	30.9	123
TWB19	Wall B surface 19	30.8	123
TWB20	Wall B surface 20	31.6	123
TWB21	Wall B surface 21	30.7	123
TWB22	Wall B surface 22	30.7	123
TWB23	Wall B surface 23	30.6	123
TWB24	Wall B surface 24	30.6	123
TWB25	Wall B additional 1, the same height of initiating module	29.3	123
TWB26	Wall B additional 2, the same height of initiating module	29.2	123
TWB27	Wall B additional 3, the same height of initiating module	29.5	123
	Ambient	28.2	-
Remark: please see Attachment 4 for thermocouple locations and Attachment 6 for monitored temperature charts.			

UNIT LEVEL

Attachment 1: Product description

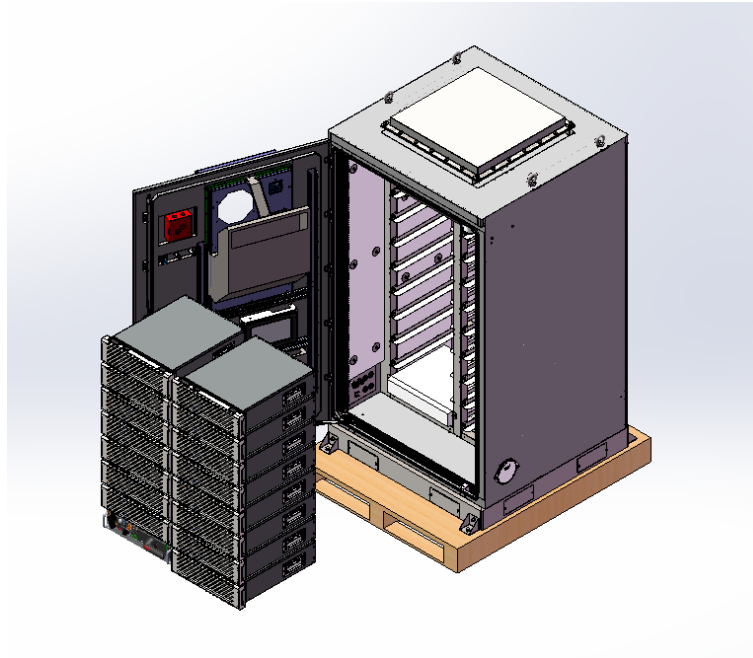

Attachment 2: Exploded-view drawing of module & Identification/location of cells within the module

Exploded-view drawing of module as below:

UNIT LEVEL

Identification/location of cells within the module as below (Cell 4 as initiating cell):

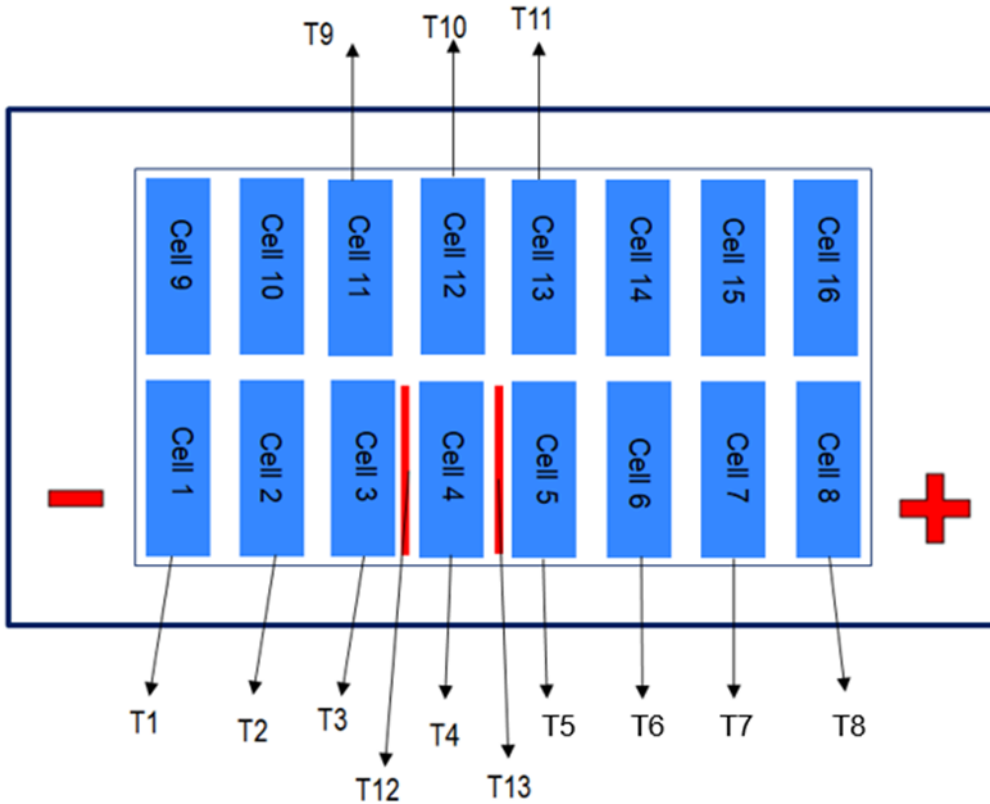

Attachment 3: Pre-conditioning profile

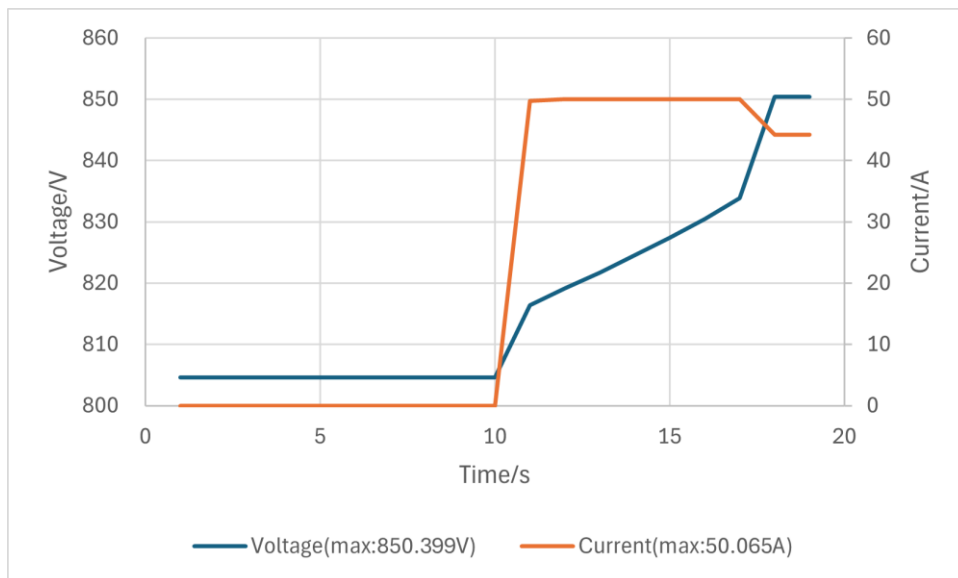
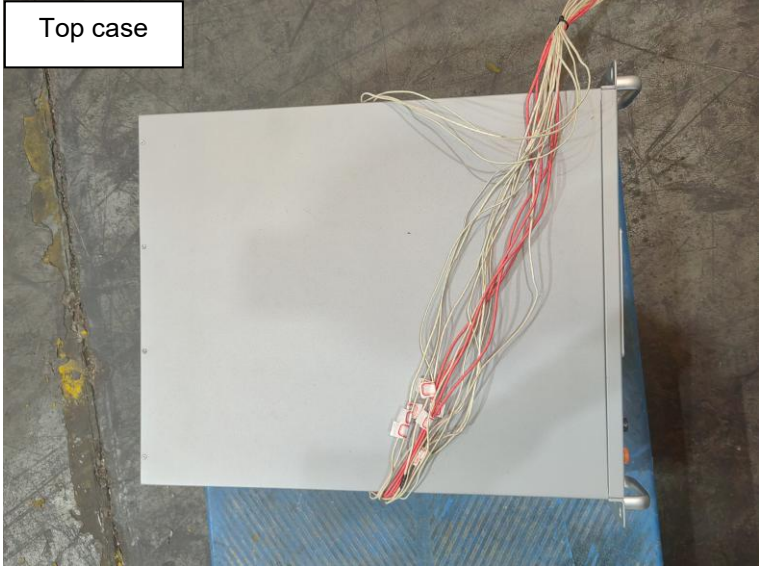



Figure 1 of Attachment 3: Pre-condition for the initiating unit

UNIT LEVEL

Attachment 4: Photo of sample before test and test setup with thermocouple location

Details of:	Figure 1 of Attachment 4: Overview of initiating module before test
	<div style="border: 1px solid black; padding: 5px; width: fit-content; margin-bottom: 5px;">Top case</div> 

Details of:	Figure 2 of Attachment 4: Overview of initiating module before test
	<div style="border: 1px solid black; padding: 5px; width: fit-content; margin-bottom: 5px;">Front case</div> 

UNIT LEVEL

Details of:	Figure 4 of Attachment 4: Overview of initiating module before test
	 <div style="position: absolute; top: 10px; right: 10px; border: 1px solid black; padding: 2px;">Back case</div>

Details of:	Figure 5 of Attachment 4: Overview of initiating module before test
	 <div style="position: absolute; top: 10px; right: 10px; border: 1px solid black; padding: 2px;">Left case</div>



UNIT LEVEL

Details of:	Figure 6 of Attachment 4: Overview of initiating module before test
	<div data-bbox="507 421 683 483" data-label="Caption"> <p>Right case</p> </div> 

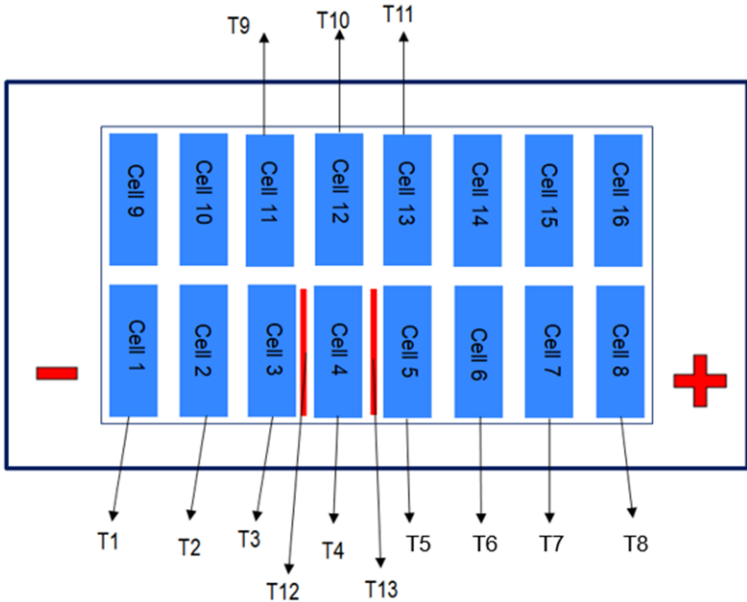
UNIT LEVEL

<p>Details of:</p>	<p>Figure 7 of Attachment 4: Overview of sample & thermocouple location of initiating module _before test</p> <div style="text-align: center;">  </div> <p>Schematic Illustration of film heaters and thermocouple locations in DUT. Cell 4 is the initiating cell. T1 to T13 means thermocouples T1 to T13. View from top.</p>
--------------------	--

UNIT LEVEL

<p>Details of:</p>	<p>Figure 8 of Attachment 4: Overview of instrumented walls before test</p> <div style="display: flex; flex-direction: column; align-items: center;"> <div style="display: flex; align-items: center; margin-bottom: 10px;"> <div style="border: 1px solid black; padding: 2px 5px; margin-right: 5px;">Wall A</div>  </div> <div style="display: flex; align-items: center;"> <div style="border: 1px solid black; padding: 2px 5px; margin-right: 5px;">Wall B</div>  </div> </div> <p>Remark: thermocouple locations of wall surface (one vertical array at 152mm intervals for the full height)</p>
--------------------	--

UNIT LEVEL

Details of:	Figure 9 of Attachment 4: Thermocouple location of initiating unit before test	
		

Details of:	Figure 10 of Attachment 4: Overview of initiating unit with the cheesecloth _before test	
		

UNIT LEVEL

Details of:

Figure 11 of Attachment 4: Overview of sample & test setup before test

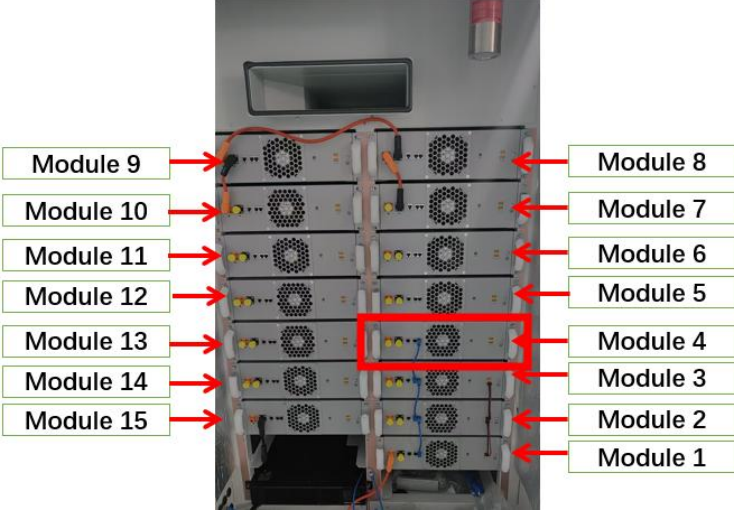
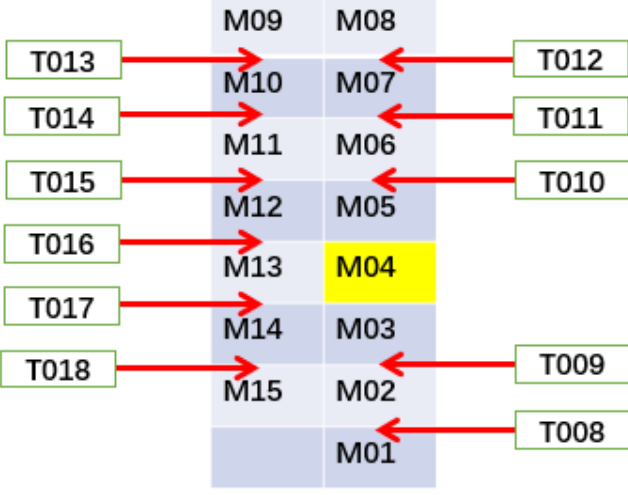

UNIT LEVEL

Details of:	<p>Figure 12 of Attachment 4: Thermocouple location for neighbour modules and other locations for samples before test</p> <div style="text-align: center;">  </div> <div style="text-align: center;">  </div> <p>T008 - T018: Centre of Module cover</p>
-------------	---

UNIT LEVEL

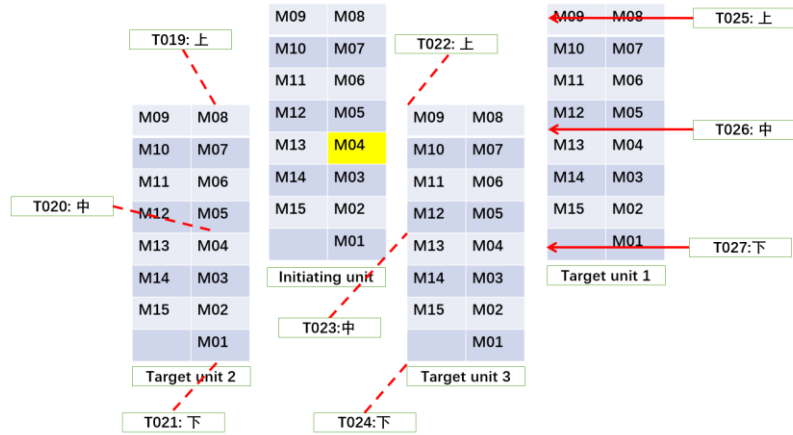

Inside the cabinet:

- TA19 - TA21: Centre of the base/mid-section/top at the rear door inside the cabinet (target unit 2)
- TA22 - TA24: At the base/mid-section/top of the rear left corner inside the cabinet (target unit 3)
- TA25 - TA27: Centre of the base/mid-section/top at the interior left wall of the cabinet (target unit 1)

Outside the cabinet:

- TA28 - TA33: The 6 faces of the initiating unit
- TA34 - TA39: The 6 faces of the target unit 1
- TA40 - TA45: The 6 faces of the target unit 2
- TA46 - TA51: The 6 faces of the target unit 3

Remark:

Target Unit 1 is a cabinet equipped with 15 empty shell modules.
Target Unit 2/3 are empty cabinets.

UNIT LEVEL

Details of: **Figure 13 of Attachment 4: Location of the heat flux sensors**

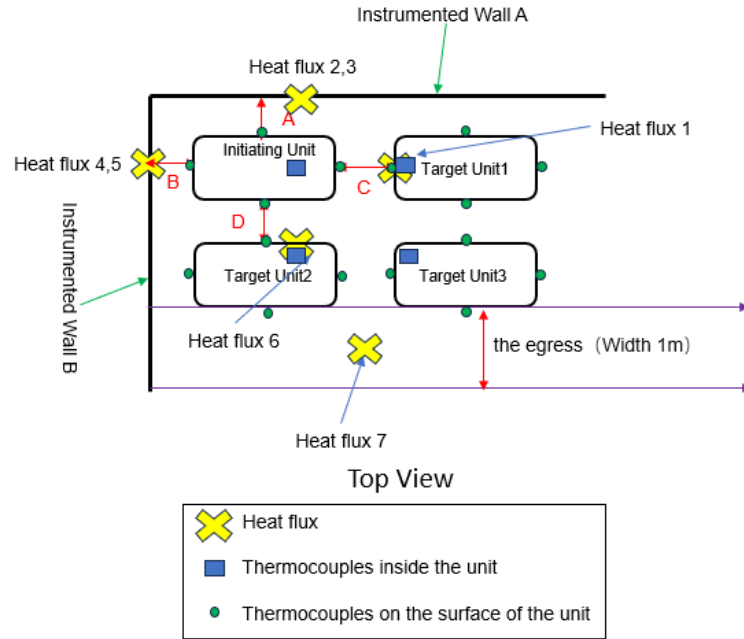

Remark:

- Heat flux 1: Positioned at the target unit 1 faced to the initiating module of the initiating unit
- Heat flux 2: Positioned at the wall A faced to the initiating module of the initiating unit
- Heat flux 3: Positioned at the wall A faced to the initiating module, potential propagation of thermal runaway
- Heat flux 4: Positioned at the wall B faced to the initiating module of the initiating unit
- Heat flux 5: Positioned at the wall B faced to the initiating module, potential propagation of thermal runaway
- Heat flux 6: Positioned at the target unit 2 faced to the initiating module of the initiating unit
- Heat flux 7: Positioned at the middle of the egress

Remark: A=B=D=1168.4mm; C=304.8 mm

Item	Height, mm	Distance to Instrumented wall A, mm	Distance to Instrumented wall B, mm
Heat flux 1	831.5	1764.9	2573.2
Heat flux 2	831.5	0	1993.4
Heat flux 3	974.5	0	1993.4
Heat flux 4	831.5	1764.9	0
Heat flux 5	974.5	1764.9	0
Heat flux 6	831.5	3529.8	1993.4
Heat flux 7	831.5	5222.8	2420.8

UNIT LEVEL

Attachment 5: Photo for sample after test

Details of:	Figure 1 of Attachment 5: Overview of sample after test
	

UNIT LEVEL

Details of:	Figure 2 of Attachment 5: Overview of initiating unit with the cheesecloth after test
	

Details of:	Figure 3 of Attachment 5: Overview of the cheesecloth after test
	

UNIT LEVEL

Details of:	Figure 4 of Attachment 5: Overview of initiating unit after test
	

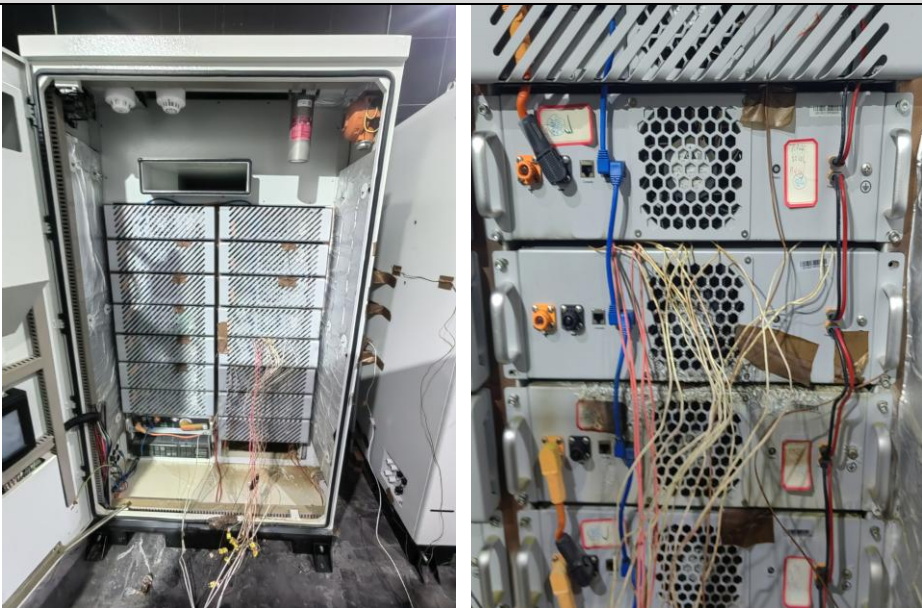
Details of:	Figure 5 of Attachment 5: Overview of initiating unit after test
	 <p style="text-align: center;">Internal view when the door is opened</p>

UNIT LEVEL

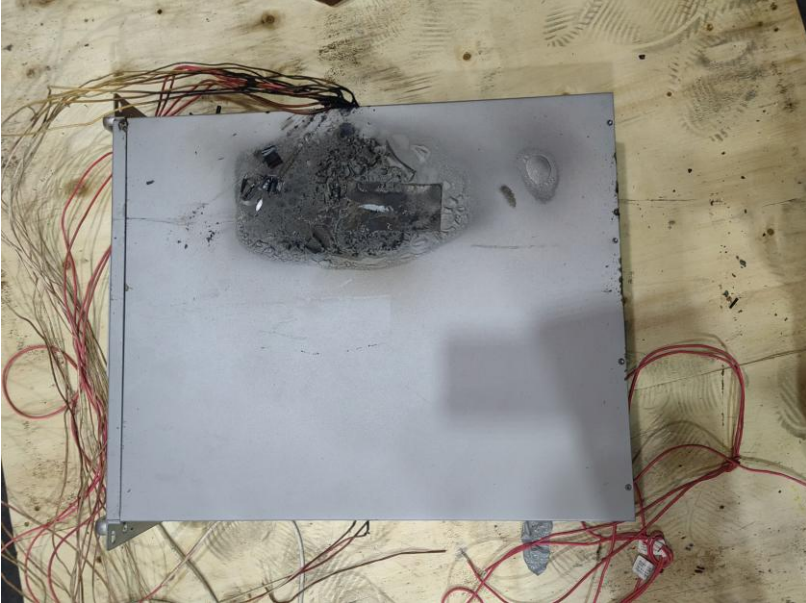
Details of:	Figure 6 of Attachment 5: Top view of initiating module after test
	

Details of:	Figure 7 of Attachment 5: Front view of initiating module after test
	

UNIT LEVEL

Details of:	Figure 9 of Attachment 5: Back view of initiating module after test
	

Details of:	Figure 10 of Attachment 5: Left side view of initiating module after test
	

UNIT LEVEL

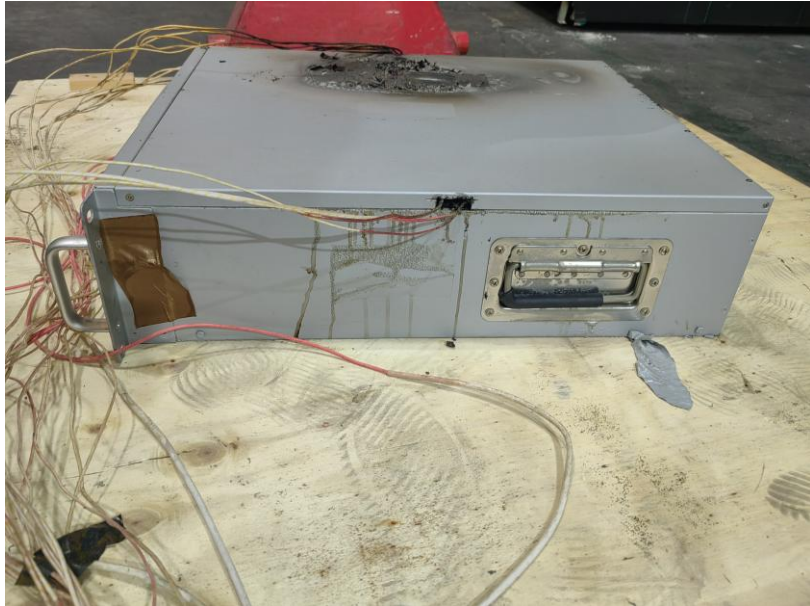
Details of:	Figure 11 of Attachment 5: Right side view of initiating module after test
	

Details of:	Figure 12 of Attachment 5: Internal view of initiating module after test.
	

UNIT LEVEL

Attachment 6: Monitored voltage and temperature chart

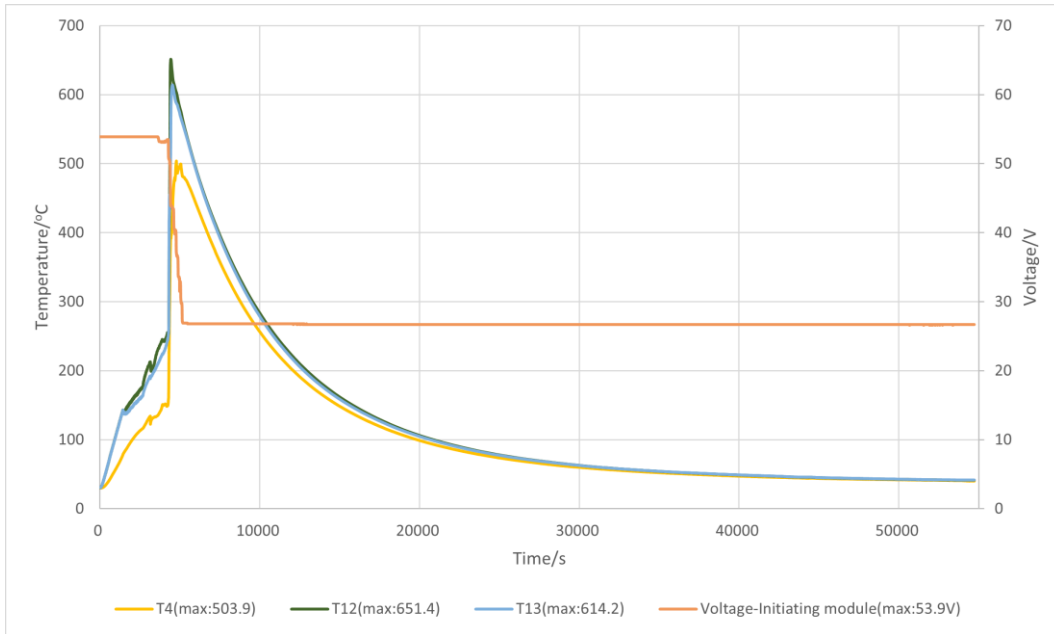

Figure 1 of Attachment 6: Temperatures of initiating cell in initiating module and voltage of initiating module.

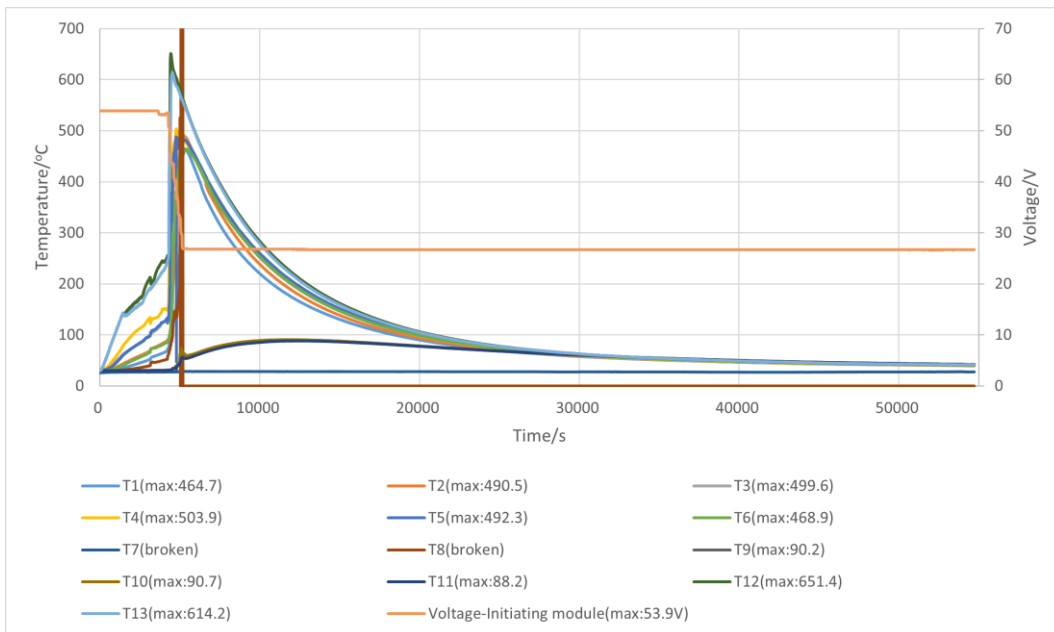

Figure 2 of Attachment 6: Temperatures of all cells within initiating module.

Remark: Two temperature sensors, T7 and T8, were found to be faulty after the test started.

UNIT LEVEL

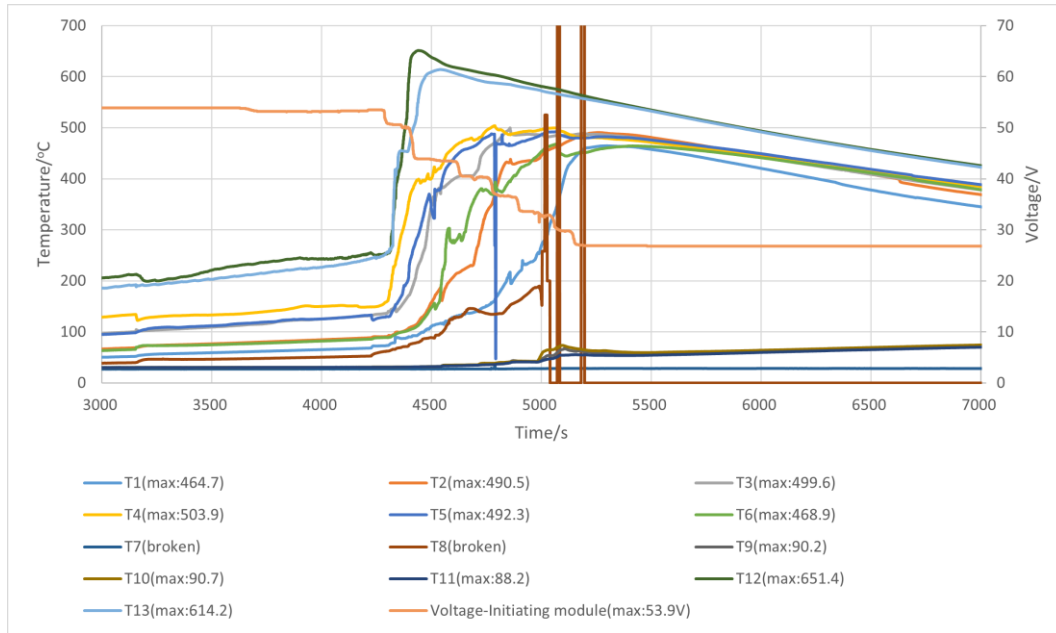

Figure 3 of Attachment 6: Zoomed view of temperatures of all cells within initiating module.
 Remark: Two temperature sensors, T7 and T8, were found to be faulty after the test started.

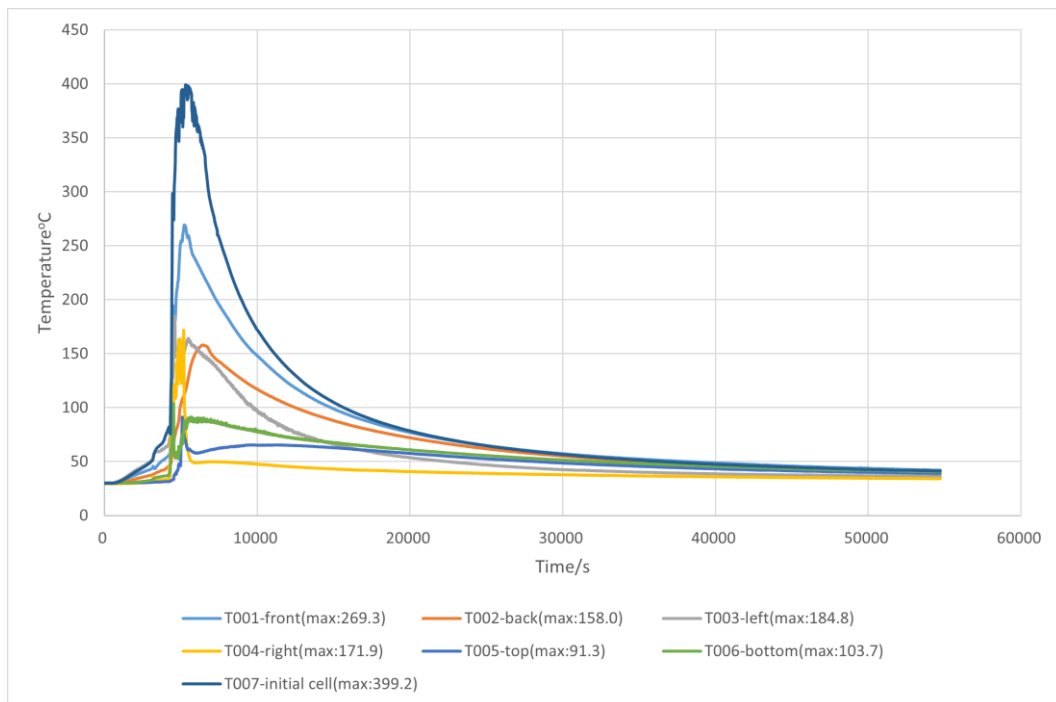

Figure 4 of Attachment 6: Temperatures of external surface temperature of initiating module.

UNIT LEVEL

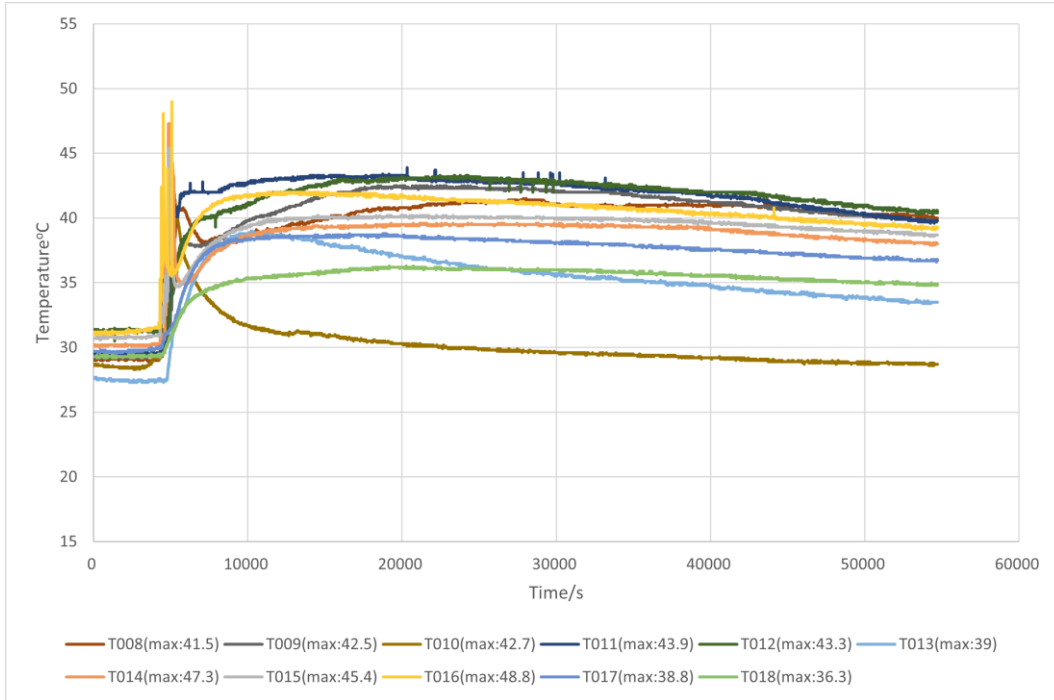

Figure 5 of Attachment 6: Temperatures of external surface temperature of other modules within initiating unit.

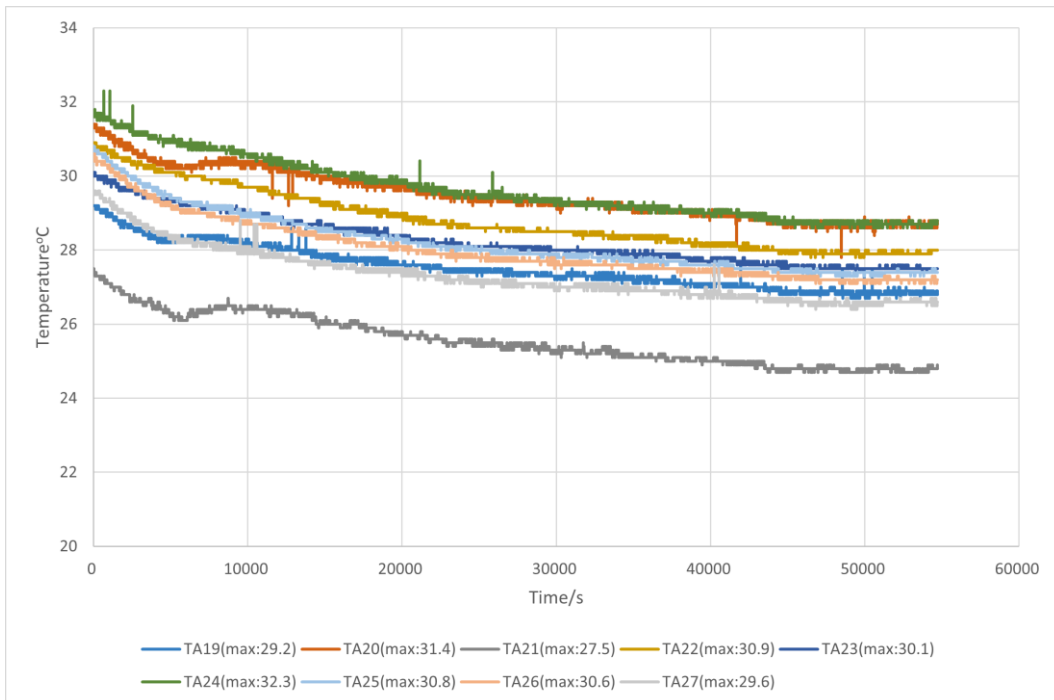

Figure 6 of Attachment 6: Temperatures of external surface of modules in target units.

UNIT LEVEL

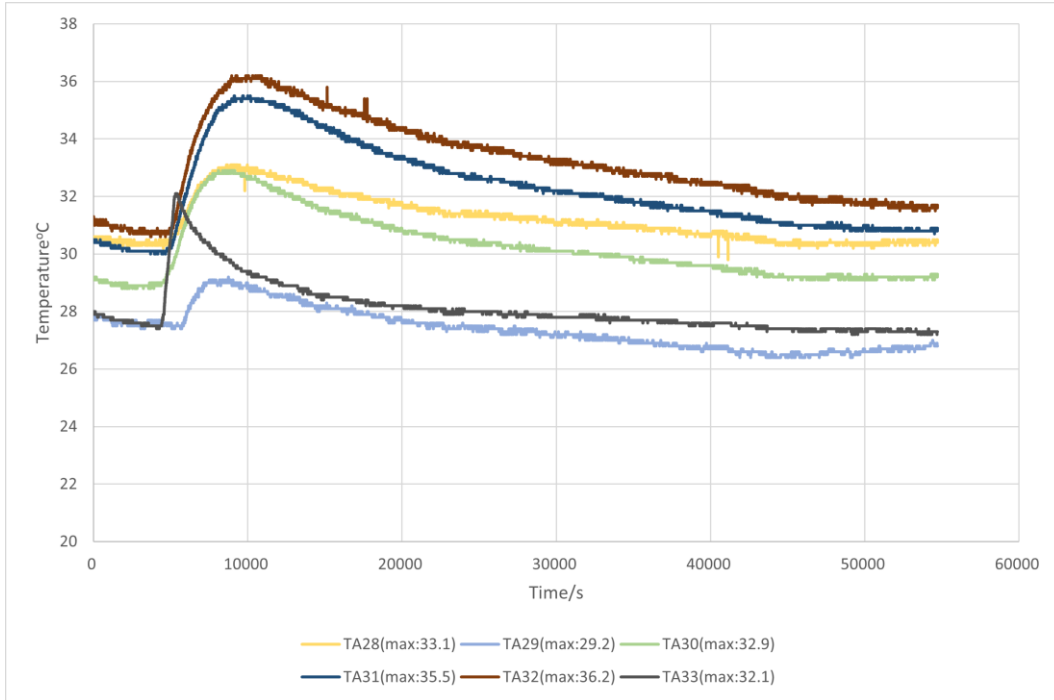

Figure 7 of Attachment 6: Temperatures of the surface of initiating unit.

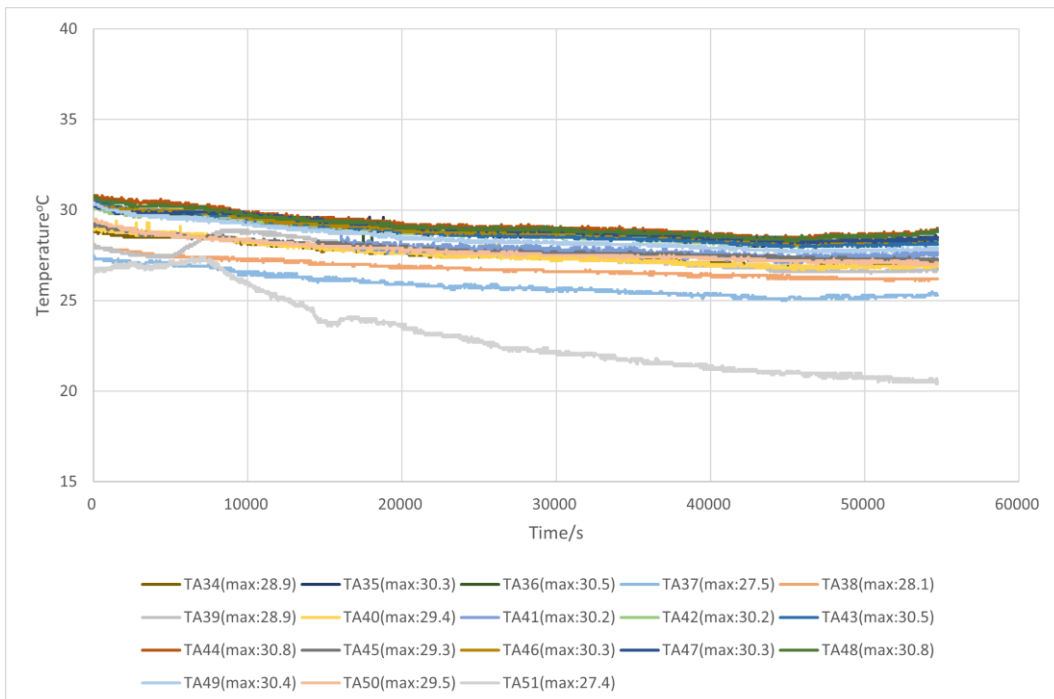

Figure 8 of Attachment 6: Temperatures of the surface of target units.



UNIT LEVEL

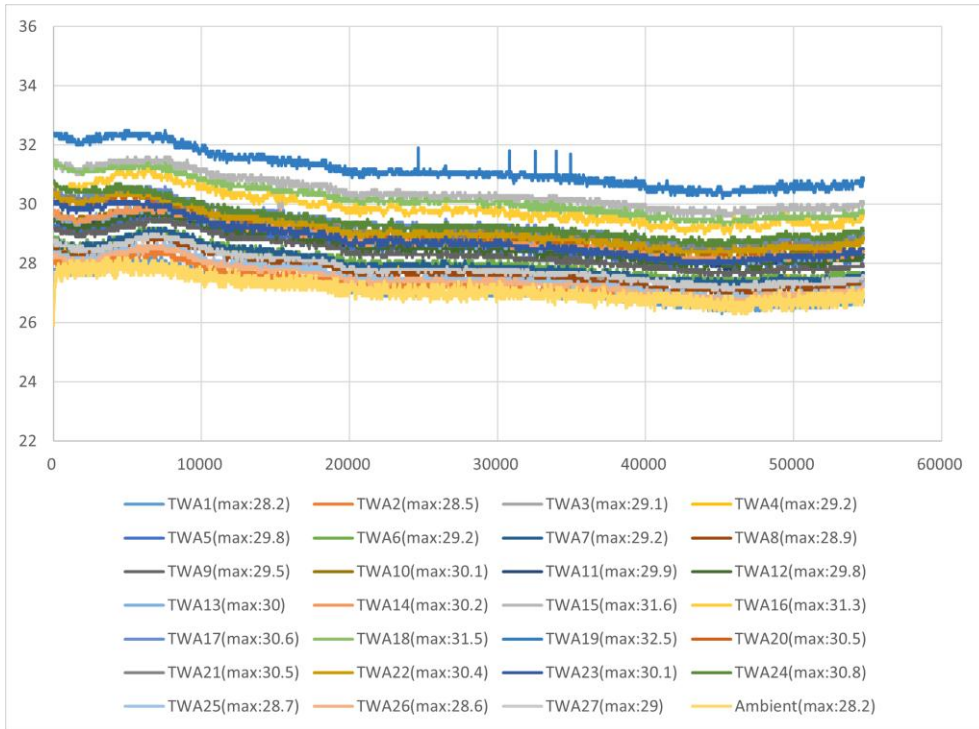

Figure 9 of Attachment 6: Temperatures of wall A surface and ambient temperature.

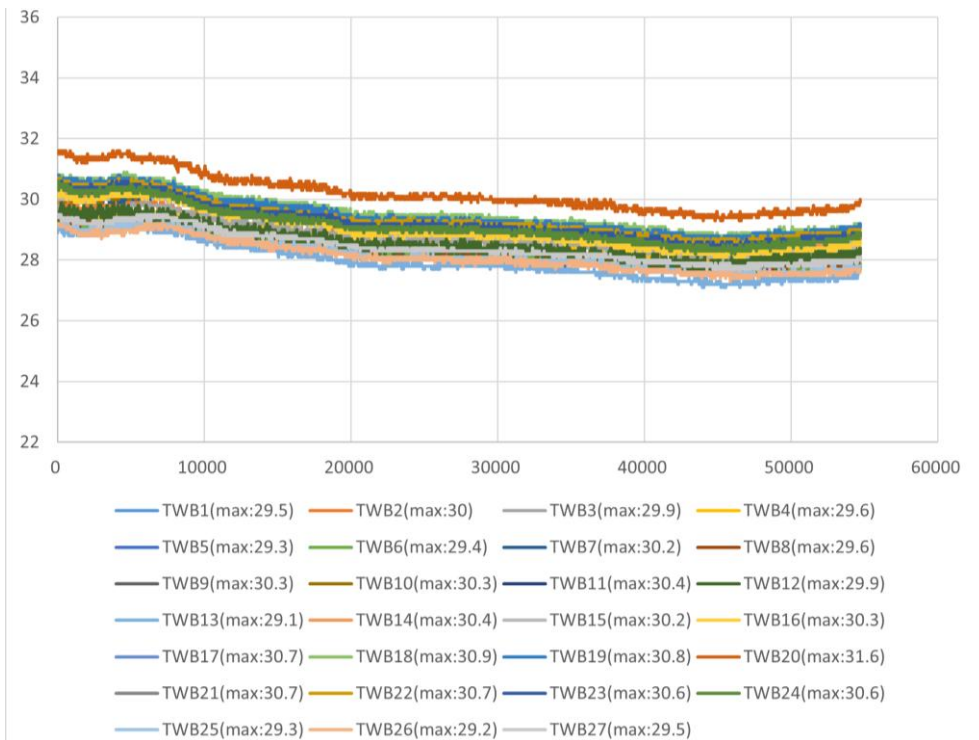

Figure 10 of Attachment 6: Temperatures of wall B surface.



UNIT LEVEL

Attachment 7: Flammable gas generation and composition data chart

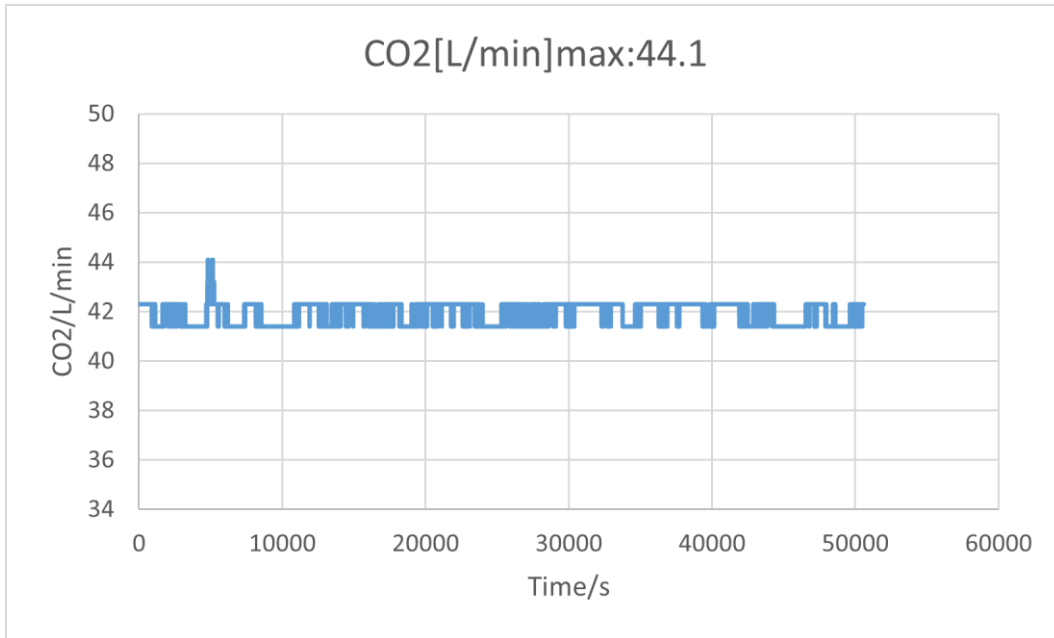

Figure 1 of Attachment 7: Gas generation and composition data chart (Measured by NDIR).

Remark: Flow rate in exhaust duct was 1.5 m³/s.

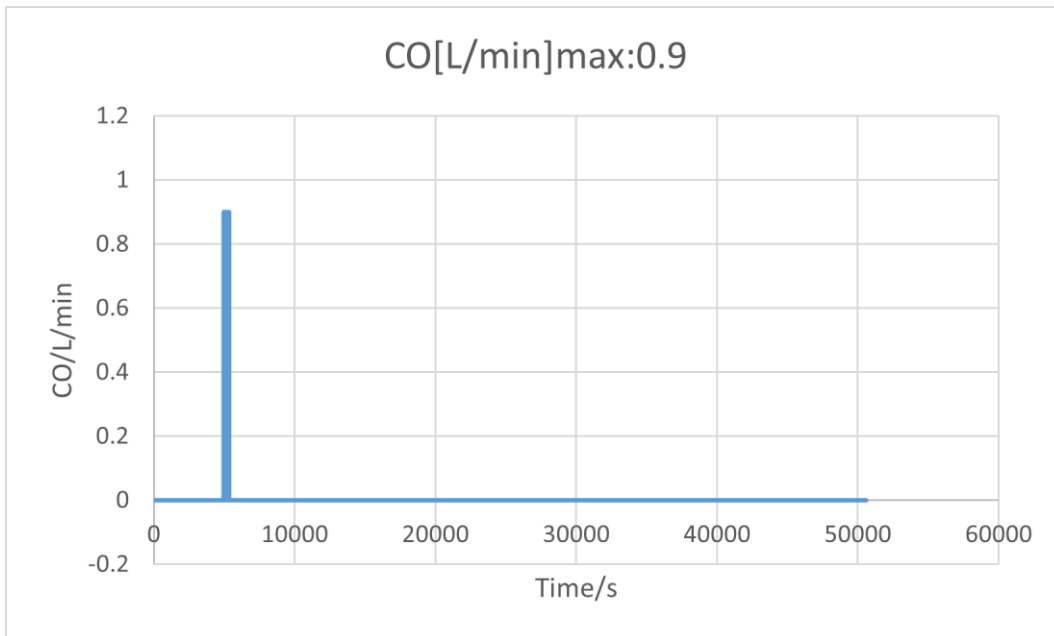

Figure 2 of Attachment 7: Gas generation and composition data chart (Measured by NDIR).

Remark: Flow rate in exhaust duct was 1.5 m³/s.

UNIT LEVEL

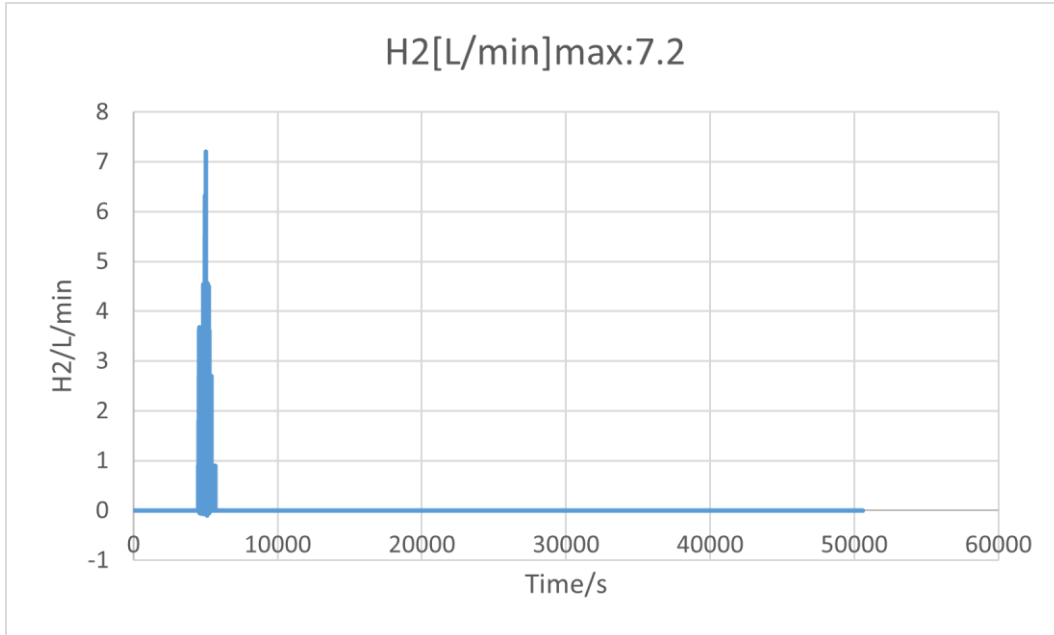

Figure 3 of Attachment 7: H₂ data chart (Measured by Hydrogen sensor).

Remark: Flow rate in exhaust duct was 1.5 m³/s.

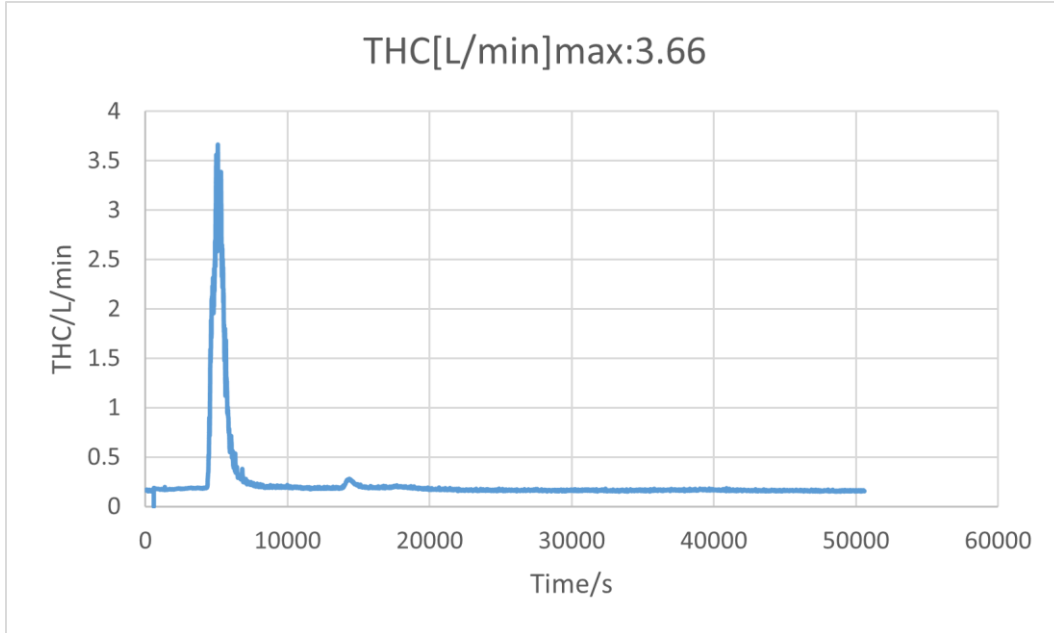

Figure 4 of Attachment 7: THC (Total Hydrocarbons) chart (Measured by FID).

Remark: Flow rate in exhaust duct was 1.5 m³/s.

UNIT LEVEL

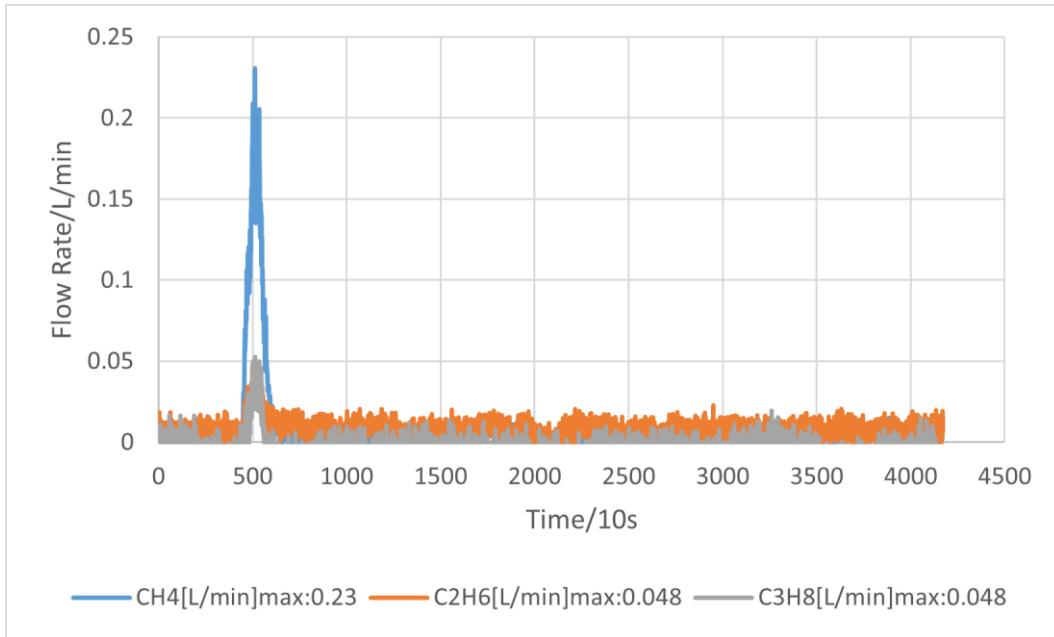

Figure 5 of Attachment 7: Gas generation and composition data chart (Measured by FTIR).

Remark: Flow rate in exhaust duct was 1.5 m³/s.

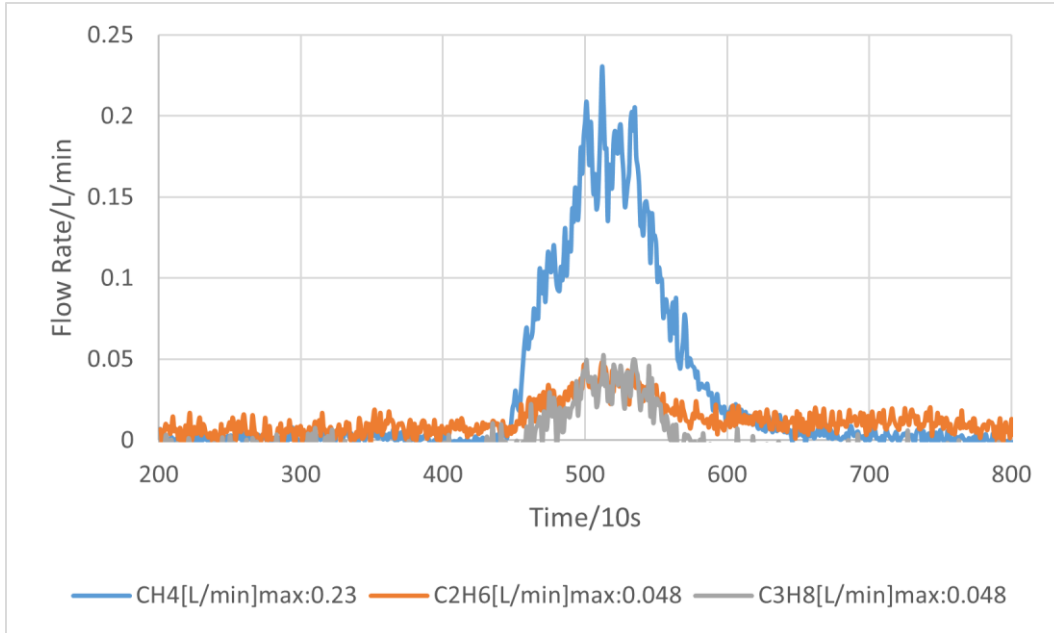
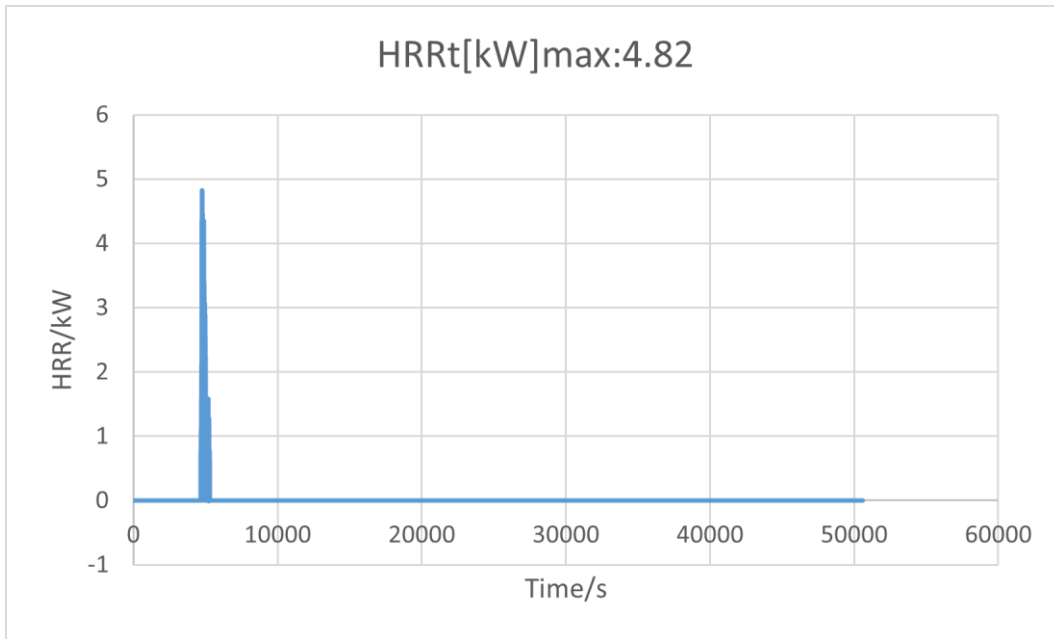

Figure 6 of Attachment 7: Zoom view of gas generation and composition data chart (Measured by FTIR).

Remark: Flow rate in exhaust duct was 1.5 m³/s.

UNIT LEVEL

Attachment 8: Heat release rate versus time data chart



Remark: No fire was detected.

Attachment 9: Peak smoke release rate and total smoke release data chart

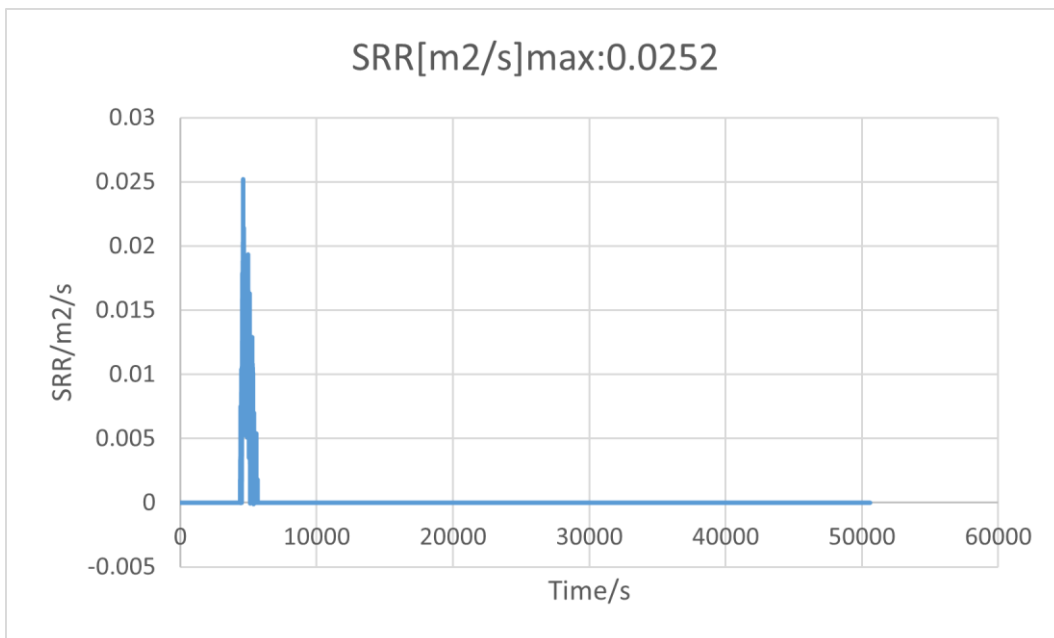



UNIT LEVEL

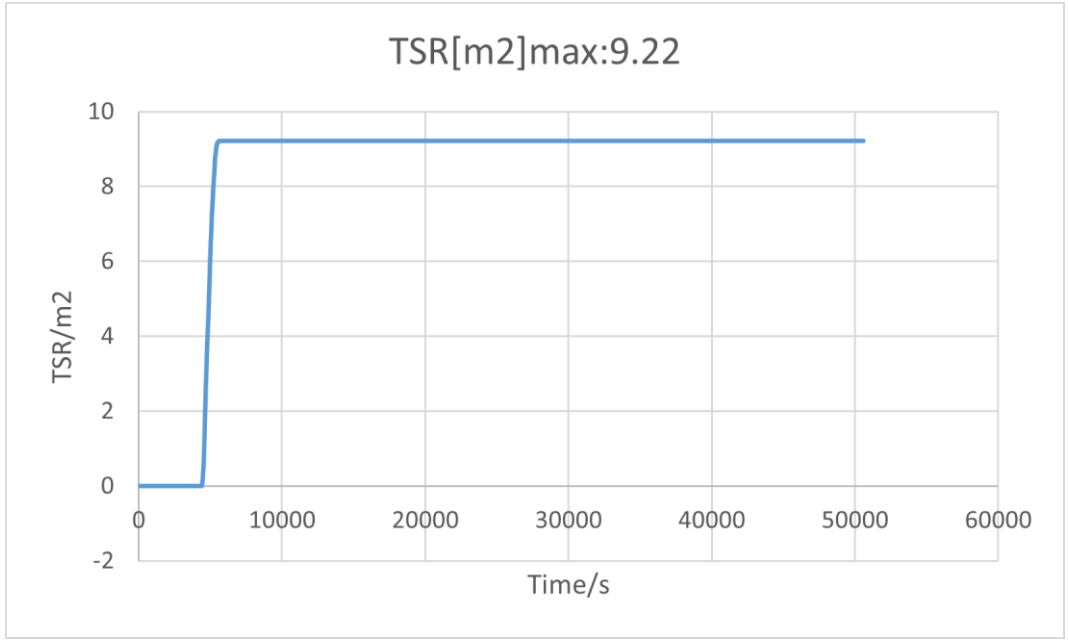

Attachment 10: Summary of Heat release rate & Peak smoke release rate and total smoke release data

Peak heat release rate	4.82 kW
Peak convective heat release rate	0 kW
Total smoke released	9.22 m ²
Peak smoke release rate	0.0252 m ² /s

Remark: No fire was detected.

----- END REPORT -----