



Quick Installation and Operation Guide

LFP Battery

PI STATION230EX



Information Version: 1.0
Release Date: 14, August 2025

Support Contact Information

In case of any technical issues with Pytes products,
please contact us at:

ess_support@pytesgroup.com

Copyright©2025 Shanghai PYTES Energy Co., Ltd.

All rights reserved.

Version: 1.0, august 2025

Subject to change without notice.



For the Pytes PI STATION230EX – Complete User Manual,
scan the QR code:

Note: This quick guide briefly describes required installation steps. Please refer to the User Manual for more detailed information.

Before Using

Warning

1. This equipment may only be installed, operated and maintained by qualified skilled person (electrician).
2. The local safety regulations and relevant operating procedures must be observed during the installation, operation and maintenance of the equipment, otherwise the equipment may get damaged. The safety precautions mentioned in the manual are only the supplement to local safety regulations.

Danger

1. Keep the Li-ion battery away from water, dust and contamination, otherwise it may cause explosion or other harmful conditions that may even lead to personal injury.
2. Do not short-circuit the Li-ion battery.
3. Observe the positive (+) and negative (-) marks on the Li-ion battery and equipment and ensure correct use. Do not reverse the Li-ion battery.
4. Do not dismantle, crush, puncture, open or shred the Li-ion battery.
5. Before removing or reconnecting with the running system, the power must be off and the system should be shut down, otherwise there will be risk of electric shock.
6. Do not expose Li-ion battery to heat or fire. In case of fire, please use dry powder fire extinguisher.
7. Do not dismantle any part of the system without contacting PYTES or PYTES authorized technical engineers. System failure caused by such will not be covered by the warranty.
8. Before operating inverter, make sure that all batteries have been started up.

Caution

1. Do not dispose of batteries in fire. The batteries may explode.
2. Do not open or mutilate batteries. Released electrolyte can prove harmful to the skin and eyes. It may be toxic.
3. A battery can present a risk of electric shock and burns by high short-circuit current.
4. A malfunctioned battery can reach temperatures that exceed the threshold of contact surface.

The following precautions should be observed when working on batteries:

- a) Disconnect the power and loads before connecting or disconnecting battery terminals;
- b) Do not wear any metal objects including watches and rings;
- c) Use tools with insulated handles;
- d) Do not lay tools or metal parts on top of batteries;
- e) Wear personal protective equipment.
- f) Make sure the battery is well grounded.

Contact with any part of a poorly grounded or ungrounded battery can cause electric shock and burns by high short-circuit current.

The risk of such hazards can be reduced if conductive surroundings are removed by a skilled person during installation and maintenance.

The battery should be charged within 12 hours when it's fully discharged or over-discharging protection mode is activated. Fail to follow this instruction will damage the battery and is not covered by warranty.



This symbol on the product means: Do not dispose of this product with general household waste. Consult your local regulations for proper disposal instructions.

Safety and Handling Instructions

Read this entire document before installing or operating the Pytes PI STATION230EX Battery (referred to as the “Battery”). Failure to do so or to follow any of the instructions or warnings in this document can result in electrical shock, serious injury, or death, or may damage the Battery and other property.

Optimize Battery Performance

1. Battery life is the amount of time your battery runs before it needs to be recharged.
2. Battery lifespan is the amount of time your battery lasts until it needs to be replaced.
3. Maximize both and you'll get the most out of your battery.

Avoid Extreme Ambient Temperatures

1. This equipment is designed to perform well in a wide range of temperatures, with Charge: $-20^{\circ}\text{C}\sim 60^{\circ}\text{C}$ ($-4^{\circ}\text{F}\sim 140^{\circ}\text{F}$).
2. Discharge: $-20^{\circ}\text{C}\sim 60^{\circ}\text{C}$ ($-4^{\circ}\text{F}\sim 140^{\circ}\text{F}$) as the ideal comfort operation zone.
3. It's important to avoid exposing your battery to ambient temperatures higher than 55°C (131°F).

Energy storage system security

1. It is forbidden to open the cabinet door while the system is running.
2. Avoid standing at the cabinet door (including within the opening range of the door) when the energy storage system is malfunctioning.
3. Emergency evacuation of the site should be carried out when the fire audible and visual alarms are triggered.
4. The energy storage system must be equipped with protective measures such as fences and walls, and safety warning signs must be erected for isolation to avoid entry of unauthorized personnel during the operation of the equipment, which may result in personal injury or property damage.

What's in the Package

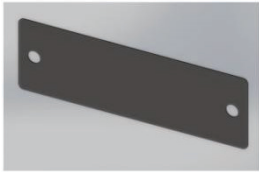

Cover Plate x 4

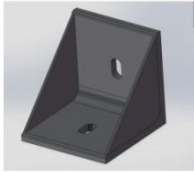

Mounting Feet x 4













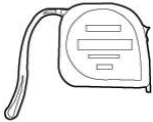

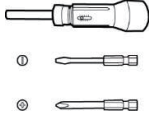



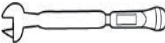













Power Cable x 4



Lifting Eye x 4

Required Personnel and Tools

 <p>Wire Stripper</p>	 <p>Pneumatic Drill</p>	 <p>Multimeter (DC Voltage Range $\geq 15000V$ DC)</p>	 <p>Steel Tape Measure</p>
 <p>Adjustable Wrench</p>	 <p>Drill 12mm</p>	 <p>Torque Screwdriver</p>	 <p>Allen Key</p>
 <p>Hammer</p>	 <p>Combination Sleeve</p>	 <p>Open-End Torque Wrench</p>	 <p>Combination Wrench</p>

 <p>Heat shrink tubing</p>	 <p>Heat Gun</p>	 <p>Zip Ties</p>	 <p>Insulated Ladder</p>
 <p>Terminal Crimping Pliers</p>	 <p>Wire Stripper</p>	 <p>Network wiring pliers</p>	 <p>Ratcheting Crimping Pliers</p>
 <p>Cable Cars</p>	 <p>Forklift Trucks</p>	 <p>Infrared Thermometer</p>	 <p>Universal Plug Conversion Socket</p>
 <p>Dust Catcher</p>	 <p>High-Voltage Insulated Gloves</p>	 <p>Safety Helmets</p>	 <p>Safety Footwear</p>
 <p>Phillips Insulated Torque Screwdriver</p>	 <p>Insulated Torque Socket Wrenches (Incl. Extensions)</p>	 <p>Insulated Torque Screwdriver</p>	 <p>Art Knife</p>

 Only trained professionals in the power system with a good knowledge of the power system is allowed to install the device.

Installation Prerequisites

- 1.The energy storage system must be installed on concrete or other noncombustible surfaces, and the mounting plane must be level, firm, and flat with sufficient bearing capacity. The installation level should be higher than the highest historical water level in the area and at least 300mm above the horizontal ground level, and the installation location should not be in a low-lying area.
- 2.The energy storage system or energy storage plant must be located in an environment free from the risk of ignition and explosion.
- 3.Choose a well-ventilated place.
- 4.Place the product on a flat,level surface to ensure stability.
- 5.Minimize dust and dirt in the installation area for optimal performance.
- 6.Ensure fire extinguishers or other fire-fighting equipment are available nearby.
- 7.Always power off the battery before performing any maintenance or adjustments.

⚠ Before installing or removing the battery, make sure that the system is disconnected from any power source and that the battery device is turned off.

PI STATION230EX

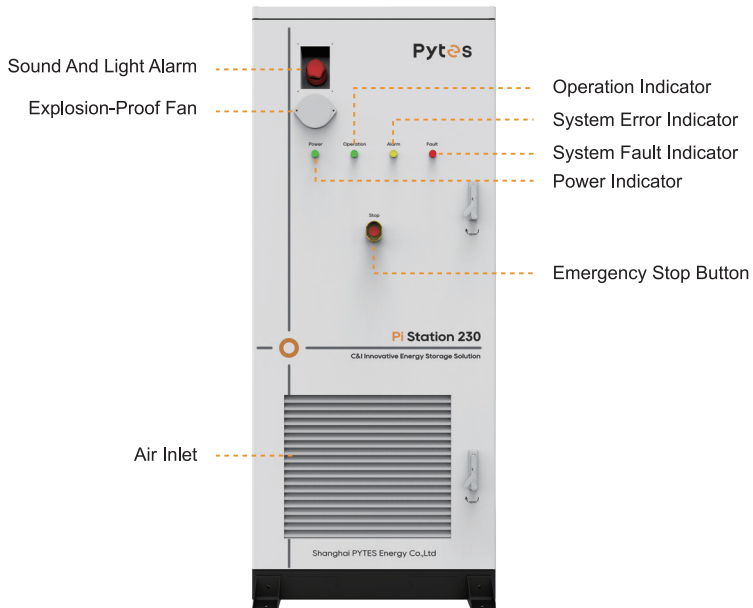

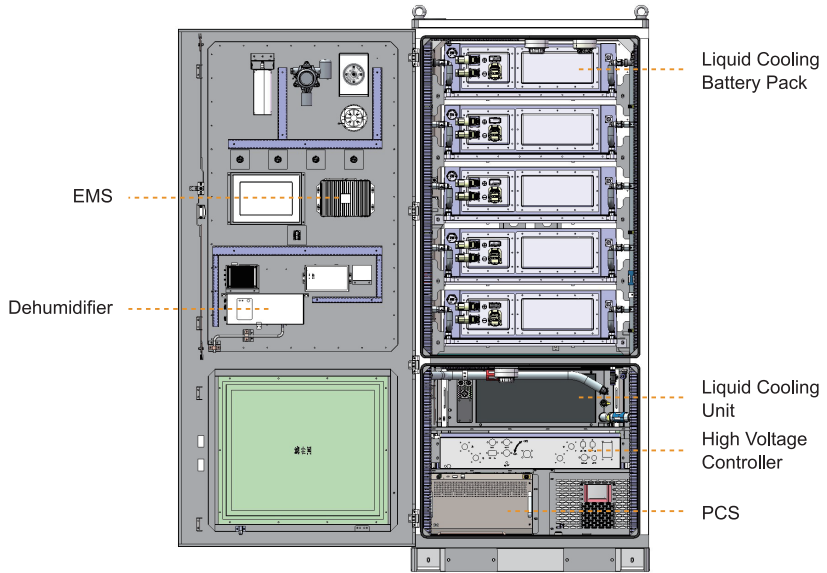

Masonry-Concrete Foundation

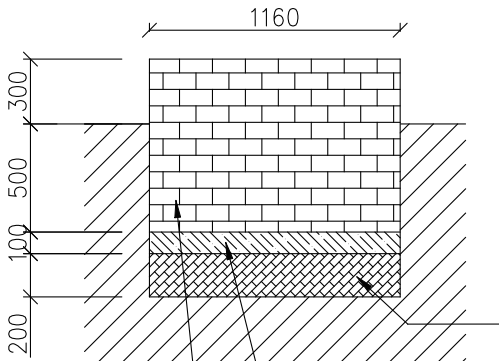

A 200mm thick crushed stone bedding layer (to be increased to 300mm thick in case of poor soil conditions); on compacted plain soil.

100mm thick C15 concrete bedding.

240×115×53mm standard red brickwork.

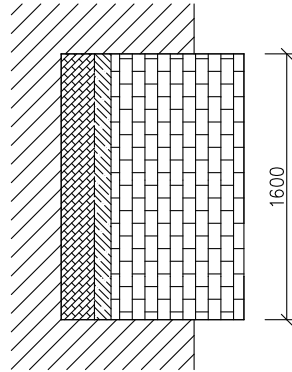
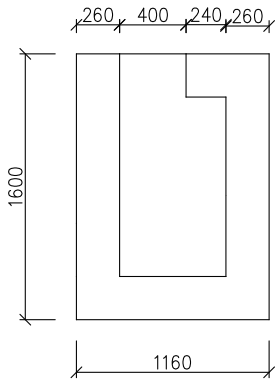

Rendering of Masonry-Concrete Foundation

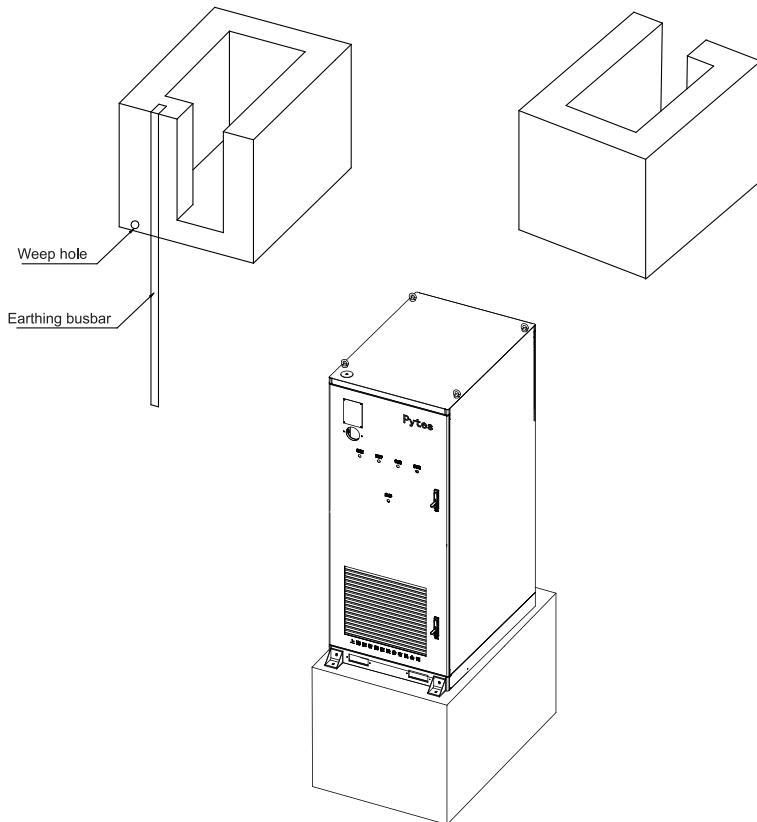

Installation

1. Product Installation

Step 1. Install the top lifting ring of the energy storage system as follow.

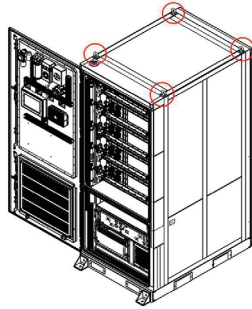

Step 2. Use a crane or forklift to place the energy storage system into the mounting position. The weight of one PI 230 device is 2.5 tonnes, so it is essential to ensure that the transportation equipment used has a load capacity of at least this amount.

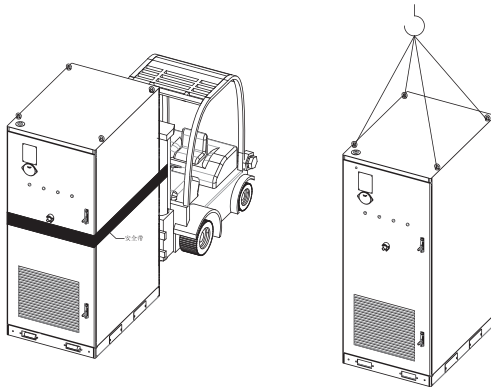

Step 3. Install the feet in the corners of the cabinet first, and use screws to secure the feet.

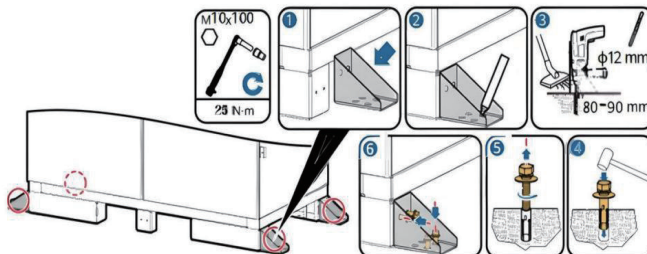

2. Electrical Connections

Step 1. Connect the positive terminal of the high voltage box to the positive terminal of BAT1 as follow.

Step 2. Connect the battery modules in series, from the negative terminal of BAT1-1 to the positive terminal of BAT1-2, and then connect the BAT1-BAT5's in sequence.

Step 3. Connect the positive terminal of the high voltage box to the positive terminal of the BAT5.

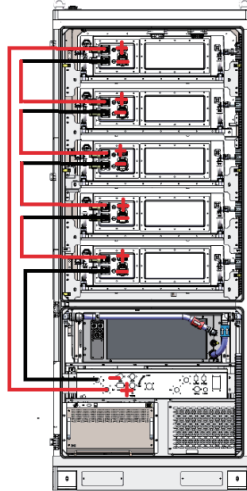

⚠ Make sure the mounting cables and equipment are not charged before installation.

Step 4. Select suitable size bolts and use a wrench to fix the connection of "L1" phase, "L2" phase, "L3" and "N" phase cables to the guillotine switch of the energy storage cabinet. Connect the ground wire securely at the grounding point.

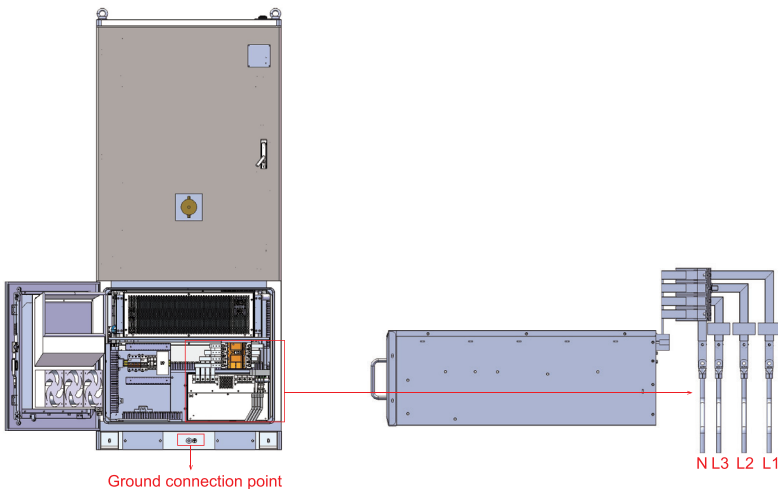

Step 5. Terminals 13 and 14 on the lower level of the double terminal strip at the rear of the energy storage cabinet are connected to terminals 21 (485A) and 22 (485B) of the inverse power meter, respectively. Only the master cabinet requires connection; the slave cabinet does not.

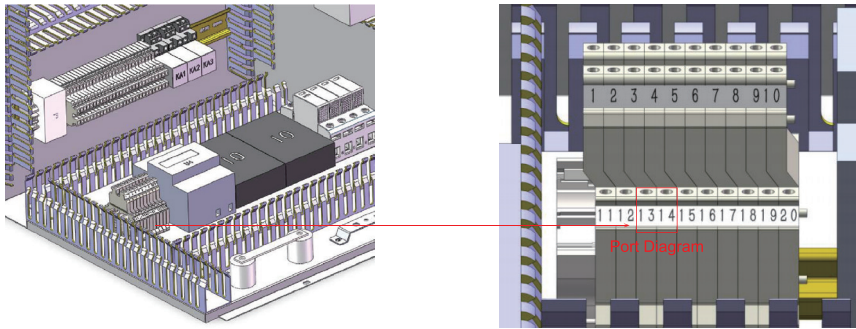

Step 6. DTST1352-CT Secondary Meter Wiring Diagram, where the DTST1352 represents the master meter on the user's grid side.

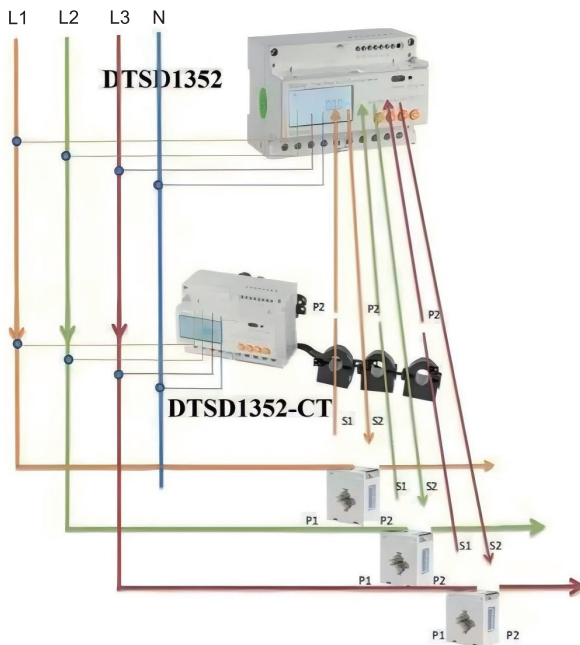

Step 7. If it is a master-slave cabinet system, the switches in the master and slave cabinets need to be interconnected via Ethernet cables.

3. Power-on operation

Note: Before starting the system, strictly check the connection terminals to ensure that the terminals are firmly connected.

Step 1. Switch the grid-connecting cabinet or grid breaker to the ON position.

Step 2. Switch the QF4 breaker to the ON position (the switch between the AC side of the liquid-cooling system and the grid).

Step 3. Switch the switches of each component of the liquid cooling system to the ON position in turn. (QF3→QF8→QF2→QF6→QF10→QF5→QF9).

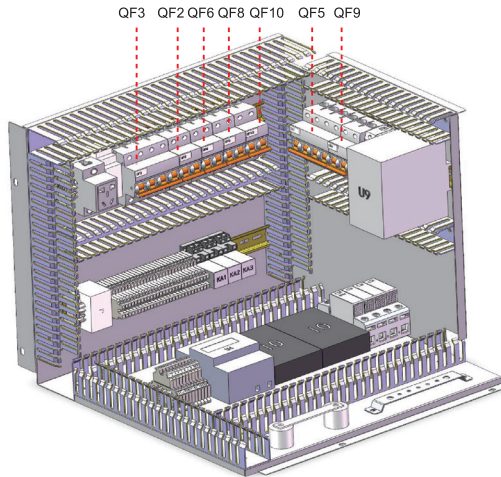

Step 4. If the UPS is not working, long press the ON button to start the UPS.

Step 5. Switch the disconnect switch on the high-voltage box to the ON position.

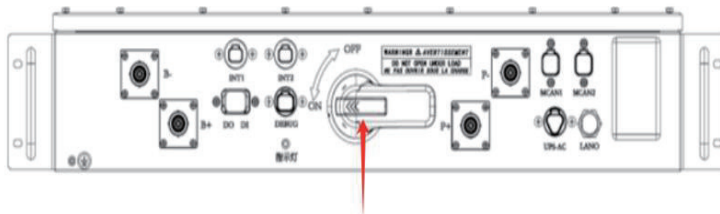

Step 6. At the Control Center - Equipment Control, close the contactor of the high-voltage box and power on the liquid cooler. Then set the operation strategy and activate it to start normal operation.

4. Power-down operation

Step 1. Log in to the cloud platform and stop the policy in "Control Center- Policy Management".

Step 2. Log in to the cloud platform, and in "Control Center- Equipment Control- Liquid Cooling Unit", turn off the liquid cooling unit when its operation status is standby.

Step 3. Switch the switches of each component of the liquid cooling system to the OFF position in turn (QF9→QF5→QF10→QF6→QF2→QF8→QF3).

Step 4. Press and hold the OFF button on the UPS to turn off the UPS.

Step 5. Turn off QF4 (the switch between the AC side of the liquid-cooling system and the power grid).

 Do not discard this document! After installation, keep it adjacent to the Battery for future reference!



Shanghai PYTES Energy Co., LTD.

Address: No. 3492 Jinqian Road, Fengxian DST, Shanghai China 201406

Email: ess_support@pytesgroup.com

Website: www.pytesess.com